



PRT-ISO16-DIN

Protege DIN Rail 16 Input Opto-Isolated Expander

Installation Manual



The specifications and descriptions of products and services contained in this document were correct at the time of printing. Integrated Control Technology Limited reserves the right to change specifications or withdraw products without notice. No part of this document may be reproduced, photocopied, or transmitted in any form or by any means (electronic or mechanical), for any purpose, without the express written permission of Integrated Control Technology Limited. Designed and manufactured by Integrated Control Technology Limited, Protege® and the Protege® Logo are registered trademarks of Integrated Control Technology Limited. All other brand or product names are trademarks or registered trademarks of their respective holders.

Copyright © Integrated Control Technology Limited 2003-2023. All rights reserved.

Last Published: 14-Feb-23 10:46 AM

Contents

Introduction	4
Installation Requirements	5
Grounding Requirements	6
Safety Grounding	6
Earth Ground Connection	6
Mounting	8
Removal	8
DC Power & Encrypted Module Network	9
Opto-Isolated Inputs	10
Trouble Inputs	10
Programmable Outputs	11
Open Collector Outputs	11
Address Configuration	12
LED Indicators	13
Status Indicator	13
Fault Indicator	13
Power Indicator	13
Output Indicators	13
Input Status Indicators	14
Error Code Indication	15
Error Code Display	15
Mechanical Diagram	16
Mechanical Layout	17
Technical Specifications	18
New Zealand and Australia	19
European Standards	20
UK Conformity Assessment Mark	22
FCC Compliance Statements	23
Industry Canada Statement	24
Disclaimer and Warranty	25

Introduction

The Protege DIN Rail 16 Input Opto-Isolated Expander extends the number of inputs on the system by 16, allowing monitoring of a wide range of open contact sensors for security, elevator control and building automation purposes.

Flexible module network architecture allows large numbers of modules to be connected to the RS-485 module network. Up to 250 modules can be connected to the Protege system in any combination to the network, over a distance of up to 900M (3000ft). Further span can be achieved with the use of a network repeater module.

The current features of the isolated input expander include:

- Secure encrypted RS-485 module communications
- 16 opto-isolated inputs
- Industry standard DIN rail mounting
- Online and remote upgradeable firmware

Installation Requirements

This equipment is to be installed in accordance with:

- The product installation instructions
- The Local Authority Having Jurisdiction (AHJ)

Grounding Requirements

An effectively grounded product is one that is intentionally connected to earth ground through a ground connection or connections of sufficiently low impedance and having sufficient current-carrying capacity to prevent elevated voltages which may result in undue hazard to connected equipment or to persons.

Grounding of the Protege system is done for three basic reasons:

1. Safety
2. Component protection
3. Noise reduction

Safety Grounding

The object of safety grounding is to ensure that all metalwork is at the same ground (or earth) potential. Impedance between the Protege system and the building scheme ground must conform to the requirements of national and local industrial safety regulations or electrical codes. These will vary based on country, type of distribution system and other factors. The integrity of all ground connections should be checked periodically.

General safety dictates that all metal parts are connected to earth with separate copper wire or wires of the appropriate gauge.

Earth Ground Connection

The DIN rail enclosure and the DIN rail modules must be grounded to a suitable single-point earth ground connection in the installation. A minimum 14AWG solid copper wire (or thicker, in accordance with local authorities) shall be used from the Protege system's earth connection points.

The DIN rail enclosure includes an earth ground single-point link connection via the metallic enclosure. This single-point link is the Protege system's earth ground. All modules that have earth ground connections and that are installed in the same enclosure shall be connected to this single point. A single-point earth ground connection avoids the creation of ground loops in the system and provides a single reference point to earth ground.

DIN Rail Ground Connections (one or more cabinets installed in the same room)

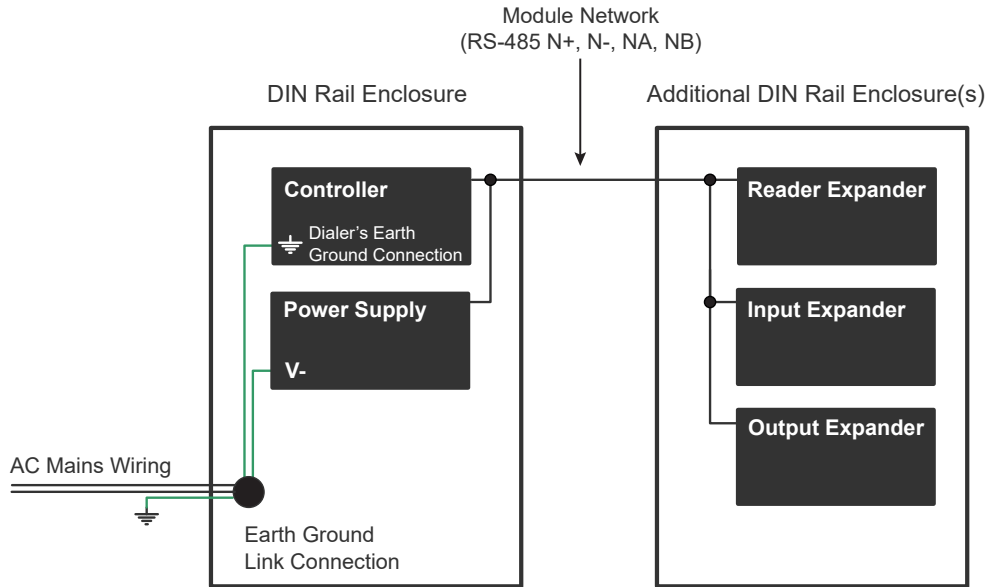

DIN Rail Ground Connections (multiple cabinets in different rooms, sectors, or buildings)

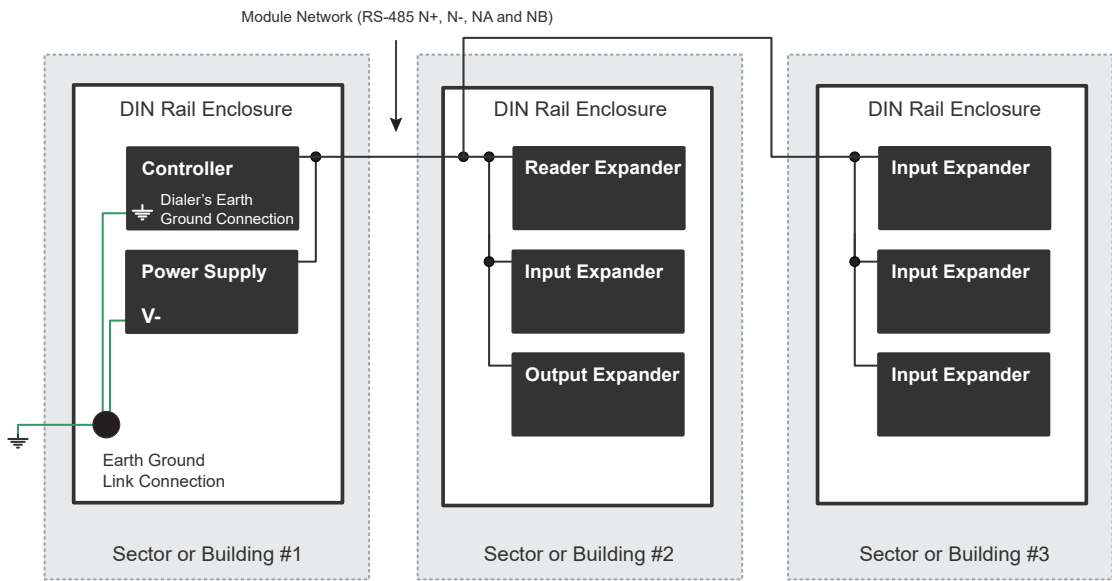

The Dialer's Earth Ground Connection applies to modem model controllers only.

Note that the DIN rail enclosure earth terminal is connected to the power supply V- terminal.

There must be only **one** single earth grounding point per system.

Mounting

Protege DIN rail modules are designed to mount on standard DIN rail either in dedicated DIN cabinets or on generic DIN rail mounting strip.

When installing a DIN rail module, ensure that there is adequate clearance around all sides of the device and that air flow to the vents of the unit is not restricted. It is recommended that you install the module in a location that will facilitate easy access for wiring. It is also recommended that the module is installed in an electrical room, communication equipment room, secure cabinet, or in an accessible area of the ceiling.

1. Position the DIN rail module with the labeling in the correct orientation.
2. Hook the mounting tabs (opposite the tab clip) under the edge of the DIN rail.
3. Push the DIN rail module against the mount until the tab clips over the rail.

Removal

A Protege DIN rail module can be removed from the DIN rail mount using the following steps:

1. Insert a flat blade screwdriver into the hole in the module tab clip.
2. Lever the tab outwards and rotate the unit off the DIN rail mount.

DC Power & Encrypted Module Network

The expander incorporates encrypted RS-485 communications technology, and both module and network power are supplied by the N+ and N- terminals.

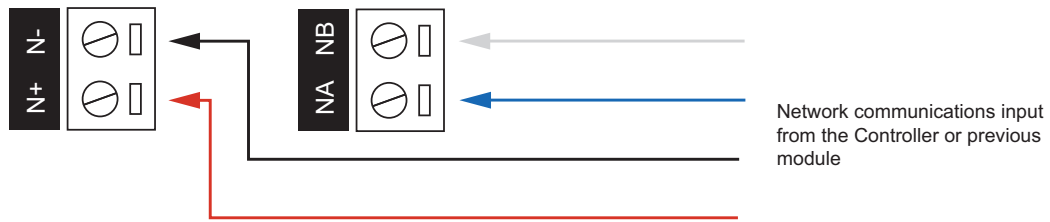

Connection of the communications and DC supply should be performed according to the diagram shown above. It is important that the N+ network communications power be 12VDC supplied from an independent battery backed power supply unit capable of supplying the required voltage to all devices on the RS-485 network.

Warning:

- The 12V N+ and N- communication input must be supplied from only **one** point. Connections from more than one 12V supply may cause failure or damage to the unit or the device supplying network power.
- The 330 ohm EOL (End of Line) resistor provided in the accessory bag **must** be inserted between the NA and NB terminals of the **first** and **last** modules on the RS-485 network. These are the modules physically located at the ends of the RS-485 network cabling.

End of Line Resistors:

First Module on RS-485 Network

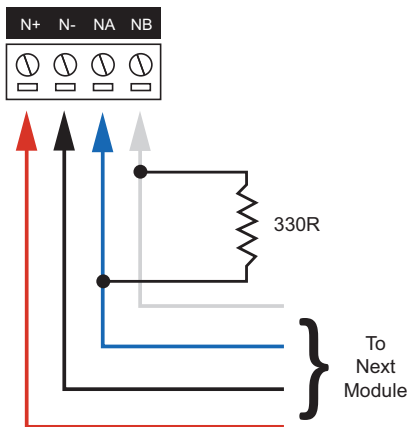

Last Module on RS-485 Network

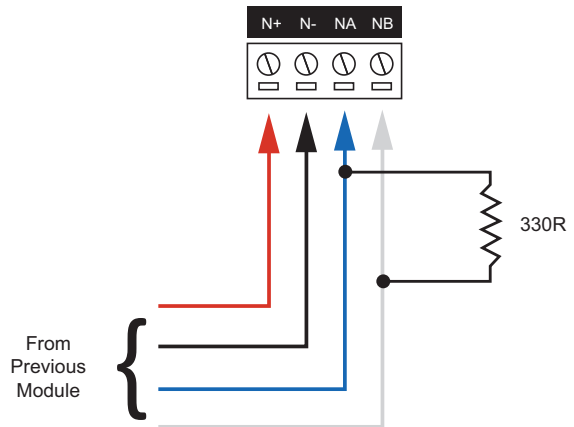

Opto-Isolated Inputs

The isolated input expander can monitor the state of up to 16 opto-isolated inputs, with each input completely isolated electrically from the others. In order for the inputs to be activated, power needs to be externally provided to the required input terminals.

Devices connected to these opto-isolated inputs can be installed to a maximum distance of 300m (1000ft) from the expander when using 22 AWG wire. Each opto-isolated input may be individually configured for normally opened and normally closed configurations.

Input Circuit Examples:

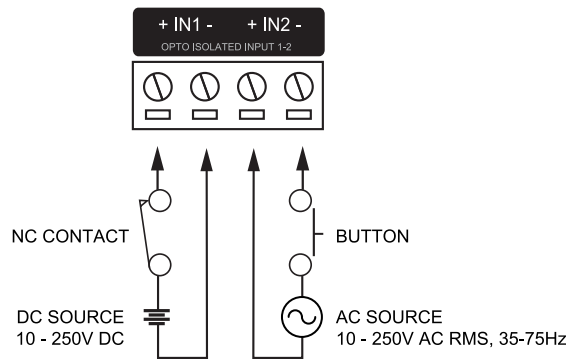

Trouble Inputs

Each isolated input expander can monitor up to 16 trouble inputs.

Trouble inputs are used to monitor the module status and in most cases are not physically connected to an external input.

The following table details the trouble inputs that are configured in the system and the trouble groups that they are associated with.

Input Number	Description	Default Trouble Group	Default Trouble Group Option
ZXxxx:01-03	Reserved	None	None
ZXxxx:04	Aux Failure	General	Power Fault
ZXxxx:05-15	Reserved	None	None
ZXxxx:16	Module Offline	System	Module Offline

Replace 'xxx' with the appropriate address of the module that you are programming.

When this module is added by the expanders wizard in Protege WX, the 'Module Offline' trouble input is incorrectly programmed with address 4. For correct operation, change the trouble input address to 16. This is a known issue.

Programmable Outputs

The isolated input expander has 4 programmable outputs. These outputs are used to activate bell sirens, lighting circuits, door locks, relay accessory products and other automation points.

Open Collector Outputs

The outputs on the isolated input expander are open collector outputs and switch to a ground connection.

Example Open Collector Output Connection (LED):

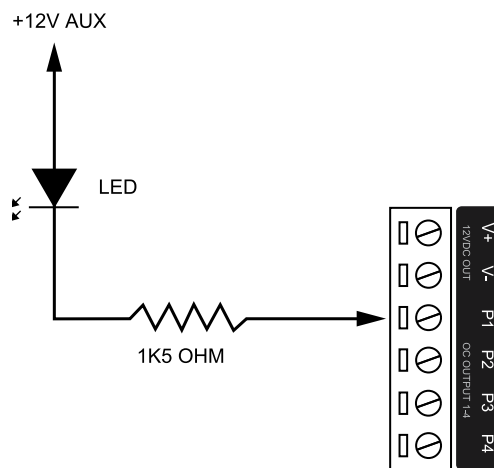

The outputs can switch to a maximum capacity of 50mA each. Exceeding this amount will damage the output.

Address Configuration

The module address is configured via programming and will require knowledge of the module serial number. The serial number can be found on the identification sticker on the product.

Refer to the Protege system controller configuration guide for address programming details.

The controller has a set limit on the number of modules of each type that it can support. When adding and configuring modules always refer to the *Maximum Module Addresses* table in the controller configuration guide.

LED Indicators

Protege DIN rail modules feature comprehensive diagnostic indicators that can aid the installer in diagnosing faults and conditions. In some cases an indicator may have multiple meanings depending on the status indicator display at the time.

Status Indicator

The status indicator displays the module status.

State	Description
Fast flash (green)	Module attempting registration with controller
Slow flash (green)	Module successfully registered with controller
Flashing (red)	Module communications activity

When the fault and status indicators are flashing alternately, the module is in identification mode, enabling the installer to easily identify the module in question. Upon either a module update or the identification time period expiring, the module will return to normal operation.

Fault Indicator

The fault indicator is lit any time the module is operating in non-standard mode. If the fault indicator is flashing, the module requires a firmware update or is in firmware update mode. When the fault indicator is on, the status indicator will flash an error code.

State	Description
Continuous slow flash (red)	Module is in boot mode awaiting firmware update
Constantly on (red)	Module is in error state and will flash an error code with the status indicator

Power Indicator

The power indicator is lit whenever the correct module input voltage is applied across the N+ and N- terminals.

State	Description
Constantly on (green)	Correct module input voltage applied
Constantly off	Incorrect module input voltage applied

Output Indicators

The output indicators will show the status of the outputs.

State	Description
Constantly on (red)	Output is ON
Constantly off	Output is OFF

Input Status Indicators

Whenever an input on the isolated input expander is programmed with an input type and area, and that area is armed, the status will be displayed on the front panel indicator (1-16) corresponding to the physical input number (IN1-IN16). This allows for easy test verification of inputs without the need to view the inputs from a keypad or the Protege software.

State	Description
Constantly off	Input is not programmed
Constantly on (green)	Input is in a CLOSED state
Constantly on (red)	Input is in an OPEN state

Error Code Indication

When the module attempts to register or communicate with the system controller a registration error can be generated indicating that it was not successful.

Error Code Display

The following table is only valid if the **fault** indicator is constantly on and the **status** indicator is flashing red.

If the fault indicator is flashing the module requires a firmware update or is currently in firmware update mode.

The status indicator will flash red with the error code number. The error code number is shown with a 250ms on and off period (duty cycle) with a delay of 1.5 seconds between each display cycle.

Flash	Error Description
1	Unknown Error Code The error code returned by the system controller could not be understood by the module.
2	Firmware Version The firmware version on the module is not compatible with the system controller. To clear this error, update the module using the module update feature in the controller's web interface.
3	Address Too High The module address is above the maximum number available on the system controller. To clear this error change the address to one within the range set on the system controller, restart the module by disconnecting the power.
4	Address In Use The address is already in use by another module. To clear this error set the address to one that is not currently occupied. Use the view network status command to list the attached devices, or the network update command to refresh the registered device list.
5	Controller Secured Registration Not Allowed The controller is not accepting any module registrations. To allow module registrations use the network secure command to change the setting to not secured.
6	Serial Number Fault The serial number in the device is not valid. Return the unit to the distributor for replacement.
7	Locked Device The module or system controller is a locked device and cannot communicate on the network. Return the unit to the distributor for replacement.

Mechanical Diagram

The mechanical diagram below outlines the essential details needed to help ensure the correct installation of the isolated input expander.

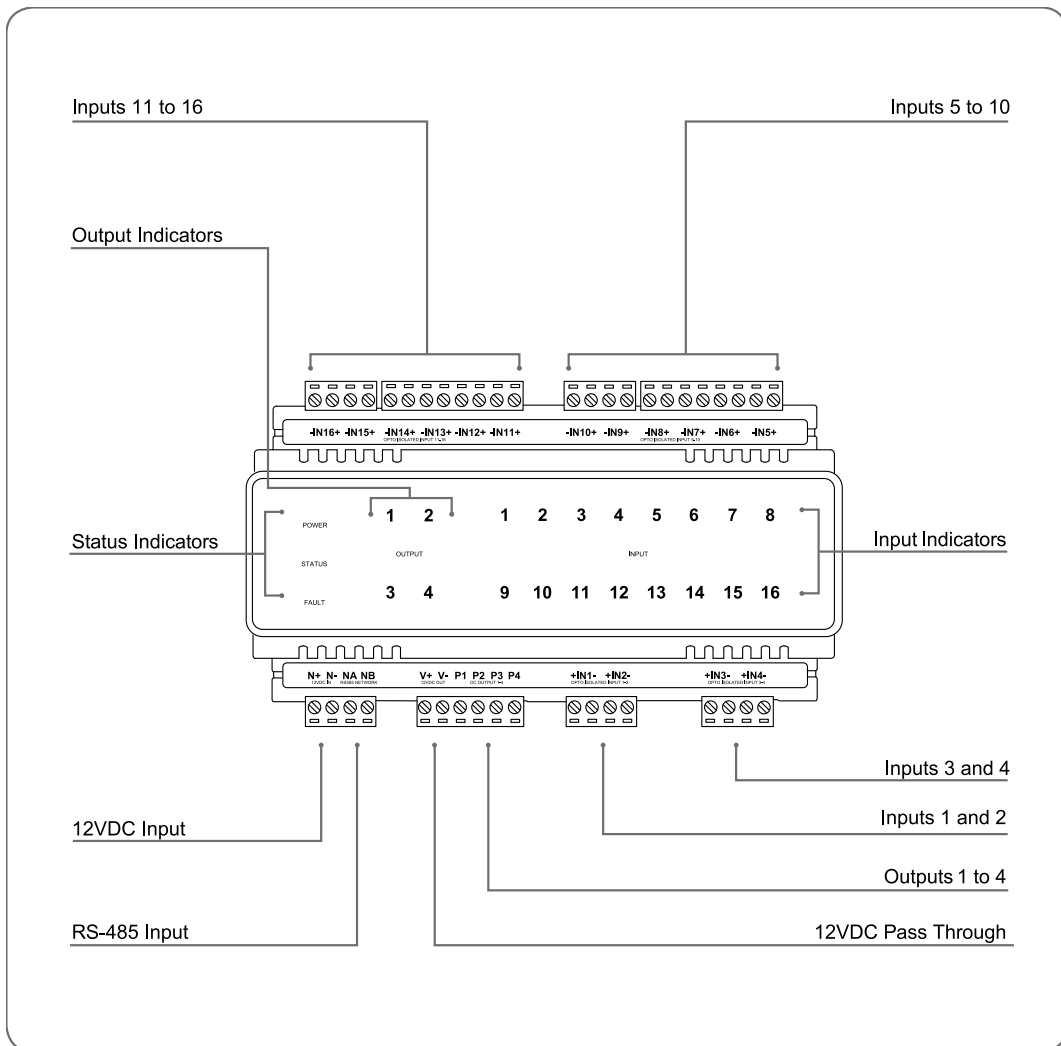

Mechanical Layout

The mechanical layout below outlines the essential details needed to help ensure correct installation and mounting. All measurements are shown in millimeters.

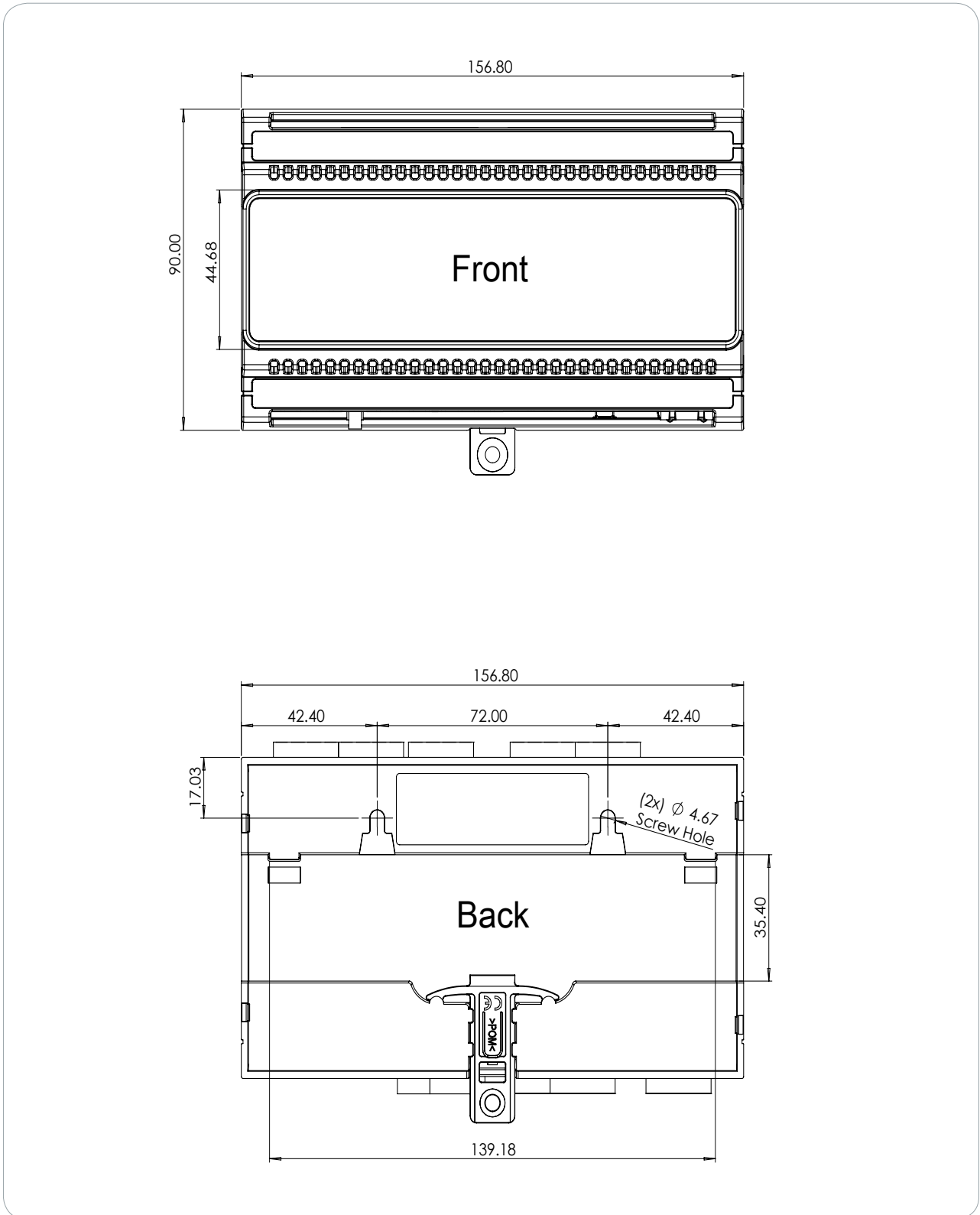

Technical Specifications

The following specifications are important and vital to the correct operation of this product. Failure to adhere to the specifications will result in any warranty or guarantee that was provided becoming null and void.

Ordering Information	
PRT-ISO16-DIN	Protege DIN Rail 16 Input Opto-Isolated Expander
Power Supply	
DC Input Voltage	11-14V DC
DC Output Voltage (DC IN Pass-Through)	10.45-13.85VDC 0.7A (Typical) Electronic Shutdown at 1.1A
Operating Current	80mA (Typical)
Low Voltage Cutout	8.7VDC
Low Voltage Restore	10.5VDC
Communication	
RS-485	Isolated Module Network
Inputs	
Operating Voltage	10V to 250V (DC/AC RMS) 35-75Hz
Input Type	16 Galvanic Isolated (10ms to 1hr Input Speed Programmable)
Input Current Draw	Current 3mA per input @ 220VDC
Outputs	
Outputs	4 (50mA Max) Open Collector
Dimensions	
Dimensions (L x W x H)	156.8 x 90 x 60mm (6.17 x 3.54 x 2.36")
Net Weight	289g (10.2oz)
Gross Weight	390g (13.8oz)
Operating Conditions	
Operating Temperature	-10° to 55°C (14° to 131°F)
Storage Temperature	-10° to 85°C (14° to 185°F)
Humidity	0%-93% non-condensing, indoor use only (relative humidity)
Mean Time Between Failures (MTBF)	784,316 hours (calculated using RFD 2000 (UTE C 80-810) Standard)

It is important that the unit is installed in a dry cool location that is not affected by humidity. Do not locate the unit in air conditioning or a boiler room that can exceed the temperature or humidity specifications.

Integrated Control Technology continually strives to increase the performance of its products. As a result these specifications may change without notice. We recommend consulting our website (www.ict.co) for the latest documentation and product information.

New Zealand and Australia

General Product Statement

The RCM compliance label indicates that the supplier of the device asserts that it complies with all applicable standards.



European Standards

CE Statement

Conforms where applicable to European Union (EU) Low Voltage Directive (LVD) 2014/35/EU, Electromagnetic Compatibility (EMC) Directive 2014/30/EU, Radio Equipment Directive (RED) 2014/53/EU and RoHS Recast (RoHS2) Directive: 2011/65/EU + Amendment Directive (EU) 2015/863.

This equipment complies with the rules, of the Official Journal of the European Union, for governing the Self Declaration of the CE Marking for the European Union as specified in the above directive(s).



Information on Disposal for Users of Waste Electrical & Electronic Equipment

This symbol on the product(s) and / or accompanying documents means that used electrical and electronic products should not be mixed with general household waste. For proper treatment, recovery and recycling, please take this product(s) to designated collection points where it will be accepted free of charge.

Alternatively, in some countries you may be able to return your products to your local retailer upon purchase of an equivalent new product.

Disposing of this product correctly will help save valuable resources and prevent any potential negative effects on human health and the environment, which could otherwise arise from inappropriate waste handling.

Please contact your local authority for further details of your nearest designated collection point.

Penalties may be applicable for incorrect disposal of this waste, in accordance with your national legislation.

For business users in the European Union

If you wish to discard electrical and electronic equipment, please contact your dealer or supplier for further information.

Information on Disposal in other Countries outside the European Union

This symbol is only valid in the European Union. If you wish to discard this product please contact your local authorities or dealer and ask for the correct method of disposal.

EN50131 Standards

This component meets the requirements and conditions for full compliance with EN50131 series of standards for equipment classification.

EN 50131-1:2006+A2:2017, EN 50131-3:2009, EN 50131-6:2008+A1:2014, EN 50131-10:2014, EN 50136-1:2012, EN 50136-2:2013, EN 60839-11-1:2013

Security Grade 4

Environmental Class II

Equipment Class: Fixed

Readers Environmental Class: IVA, IK07

SP1 (PSTN – voice protocol)

SP2 (PSTN – digital protocol)

SP6 (LAN – Ethernet) and DP1 (LAN – Ethernet + PSTN)

SP6 (LAN – Ethernet) and DP1 (LAN – Ethernet + USB-4G modem)

Tests EMC (operational) according to EN 55032:2015

Radiated disturbance EN 55032:2015

Power frequency magnetic field immunity tests (EN 61000-4-8)

EN50131

In order to comply with EN 50131-1 the following points should be noted:

- Ensure for Grade 3 or 4 compliant systems, the minimum PIN length is set for 6 digits.
- To comply with EN 50131-1 Engineer access must first be authorized by a user, therefore Installer codes will only be accepted when the system is unset. If additional restriction is required then Engineer access may be time limited to the first 30 seconds after the system is unset.
- Reporting delay –Violation off the entry path during the entry delay countdown will trigger a warning alarm. The warning alarm should not cause a main alarm signal and is not reported at this time. It can be signaled locally, visually and or by internal siren type. If the area is not disarmed within 30 seconds, the entry delay has expired or another instant input is violated, the main alarm will be triggered and reported.
- To comply with EN 50131-1 neither Internals Only on Part Set Input Alarm nor Internals Only on Part Set Tamper Alarm should be selected.
- To comply with EN 50131-1 Single Button Setting should not be selected.
- To comply with EN 50131-1 only one battery can be connected and monitored per system. If more capacity is required a single larger battery must be used.
- For Security Grade 4 installations, two forms of reporting are required. This can be satisfied using the onboard 2400bps modem included with the modem controller model, or through the incorporation of the PRT-4G-USB cellular modem module into the installation with the non-modem controller model.

Anti Masking

To comply with EN 50131-1 Grade 3 or 4 for Anti Masking, detectors with a separate or independent mask signal should be used and the mask output should be connected to another input.

I.e. Use 2 inputs per detector. One input for alarm/tamper and one input for masking.

To comply with EN 50131-1:

- Do not fit more than 10 unpowered detectors per input,
- Do not fit more than one non-latching powered detector per input,
- Do not mix unpowered detectors and non-latching powered detectors on an input.

To comply with EN 50131-1 the Entry Timer should not be programmed to more than 45 seconds.

To comply with EN 50131-1 the Bell Cut-Off Time should be programmed between 02 and 15 minutes.

EN 50131-1 requires that detector activation LEDs shall only be enabled during Walk Test. This is most conveniently achieved by using detectors with a Remote LED Disable input.

To comply with EN 50131-1, EN 60839-11 Security Grade 4 and AS/NZS2201.1 class 4&5 Vibration Detection for PreTamper Alarm, protection is provided by a DSC SS-102 Shockgard Seismic vibration sensor mounted within the system enclosure. Alarm output is provided by a pair of non-latching, N.C. (normally closed) relay contacts, opening for a minimum of 1 second on detection of an alarm connected in series with the 24Hr tamper input (TP) on the PSU (or any other system input designated/programmed as a 24Hr Tamper Alarm).

This relay is normally energized to give fail-safe operation in the event of a power loss. Indication of detection is provided by a LED situated on the front cover. The vibration sensor is fully protected from tampering by a N.C. micro switch operated by removal of the cover.

Enclosure EN-DIN-24 has been tested and certified to EN50131.

By design, the enclosures for all Integrated Control Technology products, EN-DIN-11, EN-DIN-12 and EN-DIN-24-ATTACK, comply with the EN 50131 standards. Tamper protection against removal of the cover as well as removal from mounting is provided by tamper switch.

Warning: Enclosures supplied by 3rd parties may not be EN50131-compliant, and should not be claimed as such.

UK Conformity Assessment Mark

General Product Statement

The UKCA Compliance Label indicates that the supplier of the device asserts that it complies with all applicable standards.



FCC Compliance Statements

FCC Rules and Regulations CFR 47, Part 15, Subpart B

This equipment complies with the limits for a Class A digital device, pursuant to Part 15 of the FCC rules.

Operation is subject to the following two conditions:

- This device may not cause harmful interference.
- This device must accept any interference received, including interference that may cause undesired operation.

NOTE: THE GRANTEE IS NOT RESPONSIBLE FOR ANY CHANGES OR MODIFICATIONS NOT EXPRESSLY APPROVED BY THE PARTY RESPONSIBLE FOR COMPLIANCE. SUCH MODIFICATIONS COULD VOID THE USER'S AUTHORITY TO OPERATE THE EQUIPMENT.

Industry Canada Statement

ICES-003

This class A digital apparatus complies with Canadian ICES-003.

Cet appareil numérique de la classe A est conforme à la norme NMB-003 du Canada.

CAN ICES-3 (A)/NMB-3(A)

Disclaimer and Warranty

Disclaimer: Whilst every effort has been made to ensure accuracy in the representation of this product, neither Integrated Control Technology Ltd nor its employees shall be liable under any circumstances to any party in respect of decisions or actions they may make as a result of using this information. In accordance with the ICT policy of enhanced development, design and specifications are subject to change without notice.

For warranty information, see our [Standard Product Warranty](#).

Designers & manufacturers of integrated electronic access control, security and automation products.
Designed & manufactured by Integrated Control Technology Ltd.
Copyright © Integrated Control Technology Limited 2003-2023. All rights reserved.

Disclaimer: Whilst every effort has been made to ensure accuracy in the representation of this product, neither Integrated Control Technology Ltd nor its employees shall be liable under any circumstances to any party in respect of decisions or actions they may make as a result of using this information. In accordance with the ICT policy of enhanced development, design and specifications are subject to change without notice.