



PRT-PSU-DIN-2A

Protege DIN Rail 2A Intelligent Power Supply

Installation Manual



The specifications and descriptions of products and services contained in this document were correct at the time of printing. Integrated Control Technology Limited reserves the right to change specifications or withdraw products without notice. No part of this document may be reproduced, photocopied, or transmitted in any form or by any means (electronic or mechanical), for any purpose, without the express written permission of Integrated Control Technology Limited. Designed and manufactured by Integrated Control Technology Limited, Protege® and the Protege® Logo are registered trademarks of Integrated Control Technology Limited. All other brand or product names are trademarks or registered trademarks of their respective holders.

Copyright © Integrated Control Technology Limited 2003-2023. All rights reserved.

Last Published: 31-May-23 4:25 PM

Contents

Introduction	5
Installation Requirements	6
Wiring	6
Grounding Requirements	7
Safety Grounding	7
Earth Ground Connection	7
Mounting	9
Removal	9
Cabinet Tamper Switch	9
Vibration Sensor	10
Connection	10
Modes of Operation	11
Installation Procedure	11
Wiring Diagram	13
AC Power Supply	14
Backup Battery	15
Connecting the Battery	15
Backup Battery Thresholds	16
Encrypted Module Network	17
Module Wiring	18
End of Line (EOL) Resistors	18
Output Load Connection	19
Output Current Influence on Output Load Operation	19
Core Temperature on Output Load Operation	19
Inputs	21
Trouble Inputs	21
Outputs	22
Online Mode	22
Programmable Outputs	22
Offline Mode	22
AC Fail Status Output	22
Battery Fail Status Output	23
Intelligent Monitoring	24
Monitoring Setup	24

Address Configuration	25
LED Indicators	26
Status Indicator	26
Fault Indicator	26
Power Indicator	26
V1 Output/V2 Output Indicators	26
Battery Indicator	27
Temp Indicator	27
Over Current Indicator	27
Error Code Indication	28
Error Code Display	28
Mechanical Diagram	29
Mechanical Layout	30
Technical Specifications	31
Maximum Total Output Current: UL and ULC Installations	32
New Zealand and Australia	33
European Standards	34
UK Conformity Assessment Mark	36
UL and ULC Installation Requirements	37
UL/ULC Installation Cabinet Options	37
ULC Compliance Requirements	37
CAN/ULC-60839-11-1	37
CAN/ULC-S304	38
CAN/ULC-S319	41
CAN/ULC-S559	41
UL Compliance Requirements	46
UL1610	46
UL294	47
FCC Compliance Statements	49
Industry Canada Statement	50
Disclaimer and Warranty	51

Introduction

The Protege DIN Rail 2A Intelligent Power Supply provides 12VDC power suited to powering security, access control or automation devices along with large numbers of Protege network powered modules. The power supply allows for simple and powerful monitoring of supply currents and voltages.

Flexible module network architecture allows large numbers of modules to be connected to the RS-485 module network. Up to 250 modules can be connected to the Protege system in any combination to the network, over a distance of up to 900M (3000ft). Further span can be achieved with the use of a network repeater module.

The current features of the power supply include:

- Industry standard DIN rail mounting
- Online and remote upgradeable firmware
- Secure encrypted RS-485 module communications

Installation Requirements

This equipment is to be installed in accordance with:

- The product installation instructions
- UL 294 - Access Control System Units
- UL 681 - Installation and Classification of Burglar and Holdup Systems
- UL 827 - Central-Station Alarm Services
- UL 1034 - Burglary-Resistant Electric Locking Mechanisms
- CAN/ULC-S301, Central and Monitoring Station Burglar Alarm Systems
- CAN/ULC-S302, Installation and Classification of Burglar Alarm Systems for Financial and Commercial Premises, Safes and Vaults
- CAN/ULC-S561, Installation and Services for Fire Signal Receiving Centres and Systems
- CAN/ULC-60839-11-1, Alarm and Electronic Security Systems – Part 11-1: Electronic Access Control Systems – System and Components Requirements
- The National Electrical Code, ANSI/NFPA 70
- The Canadian Electrical Code, Part I, CSA C22.1
- AS/NZS 2201.1 Intruder Alarm Systems
- The Local Authority Having Jurisdiction (AHJ)

Wiring



For UL/ULC installations the following wiring specifications must be observed.

Aux Wiring: Minimum 22AWG, maximum 16AWG (depends on length and current consumption).

For wire/cable size, a maximum of 5% voltage drop at the terminals of the powered device has to be observed.

Module Network Wiring: Recommended Belden 9842 or equivalent.

- 24AWG twisted pair with characteristic impedance of 120ohm. Maximum length 900m (3000ft).
- CAT5e / CAT6 also supported for data transmission when using ground in the same cable. Maximum length 100m (330 ft).

Do not use extra wires in the cable to power devices.

Grounding Requirements

An effectively grounded product is one that is intentionally connected to earth ground through a ground connection or connections of sufficiently low impedance and having sufficient current-carrying capacity to prevent elevated voltages which may result in undue hazard to connected equipment or to persons.

Grounding of the Protege system is done for three basic reasons:

1. Safety
2. Component protection
3. Noise reduction

Safety Grounding

The object of safety grounding is to ensure that all metalwork is at the same ground (or earth) potential. Impedance between the Protege system and the building scheme ground must conform to the requirements of national and local industrial safety regulations or electrical codes. These will vary based on country, type of distribution system and other factors. The integrity of all ground connections should be checked periodically.

General safety dictates that all metal parts are connected to earth with separate copper wire or wires of the appropriate gauge.

Earth Ground Connection

The DIN rail enclosure and the DIN rail modules must be grounded to a suitable single-point earth ground connection in the installation. A minimum 14AWG solid copper wire (or thicker, in accordance with local authorities) shall be used from the Protege system's earth connection points.

The DIN rail enclosure includes an earth ground single-point link connection via the metallic enclosure. This single-point link is the Protege system's earth ground. All modules that have earth ground connections and that are installed in the same enclosure shall be connected to this single point. A single-point earth ground connection avoids the creation of ground loops in the system and provides a single reference point to earth ground.

DIN Rail Ground Connections (one or more cabinets installed in the same room)

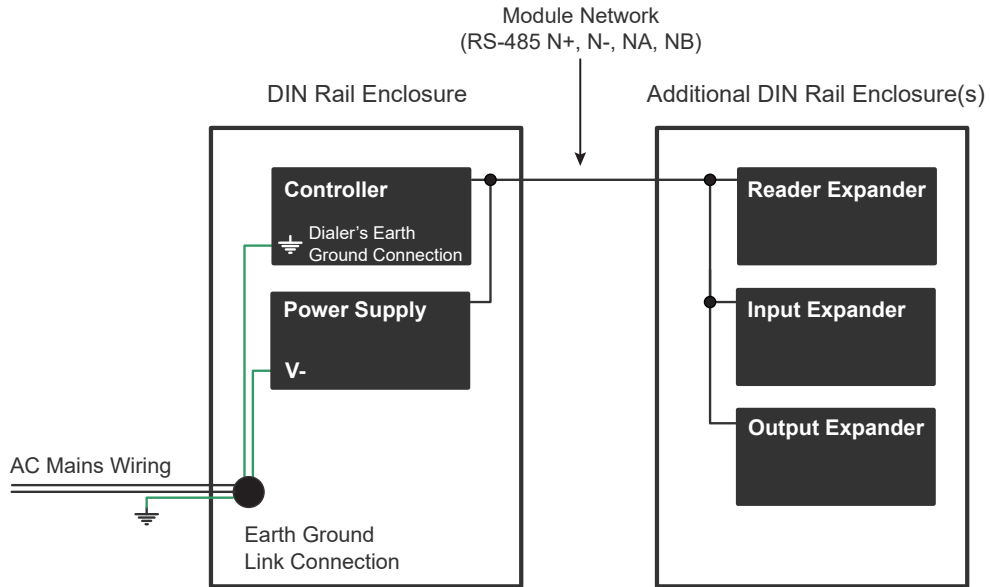

DIN Rail Ground Connections (multiple cabinets in different rooms, sectors, or buildings)

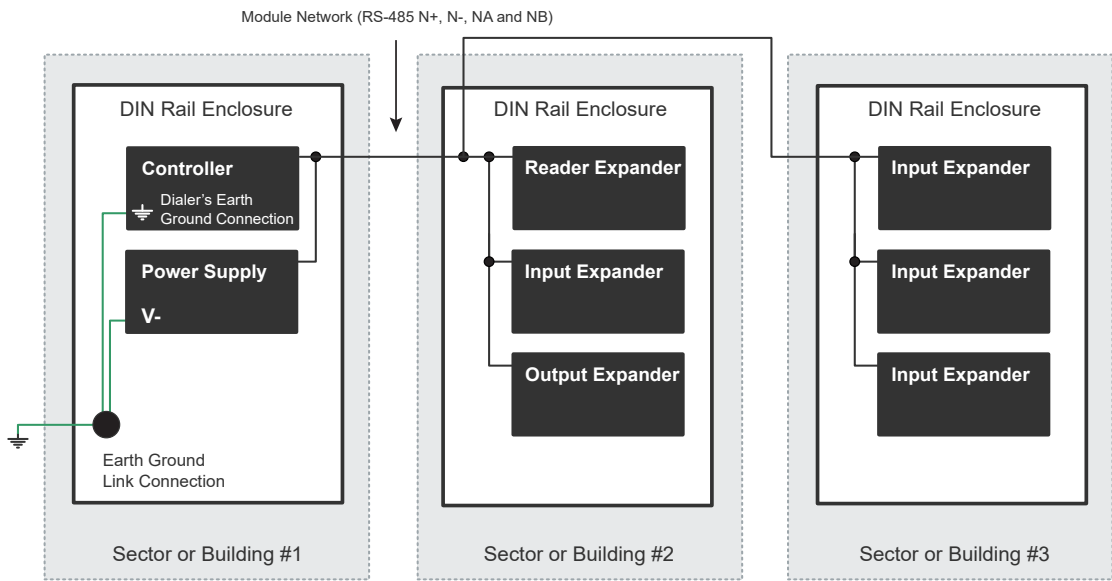

The Dialer's Earth Ground Connection applies to modem model controllers only.

Note that the DIN rail enclosure earth terminal is connected to the power supply V- terminal.

There must be only **one** single earth grounding point per system.

Mounting

Protege DIN rail modules are designed to mount on standard DIN rail either in dedicated DIN cabinets or on generic DIN rail mounting strip.

When installing a DIN rail module, ensure that there is adequate clearance around all sides of the device and that air flow to the vents of the unit is not restricted. It is recommended that you install the module in a location that will facilitate easy access for wiring. It is also recommended that the module is installed in an electrical room, communication equipment room, secure cabinet, or in an accessible area of the ceiling.

1. Position the DIN rail module with the labeling in the correct orientation.
2. Hook the mounting tabs (opposite the tab clip) under the edge of the DIN rail.
3. Push the DIN rail module against the mount until the tab clips over the rail.

Removal

A Protege DIN rail module can be removed from the DIN rail mount using the following steps:

1. Insert a flat blade screwdriver into the hole in the module tab clip.
2. Lever the tab outwards and rotate the unit off the DIN rail mount.

Cabinet Tamper Switch

The enclosure tamper input notifies the monitoring station or remote computer that the enclosure has been opened. If the tamper switch is already mounted in your ICT enclosure, simply cut the cable tie once the enclosure is in place to allow the switch to actuate. Otherwise, mount the tamper switch to the enclosure with the bracket provided.

When the tamper input switch terminals are connected in series with the dedicated tamper input (TP) and V-terminal of the power supply, it will open the trouble input AExxx:01 on the power supply. Alternatively, connect the tamper switch to any other system input designated and programmed as a 24HR tamper alarm input.

Tamper Input Connection:

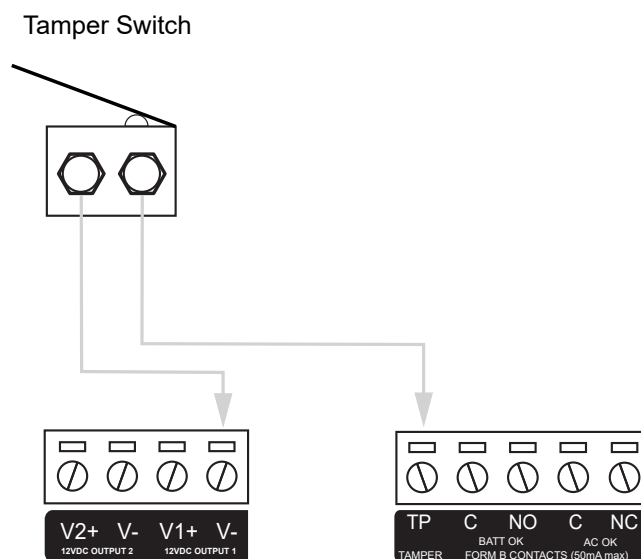

Vibration Sensor

Protection is provided by a DSC SS-102 Shockgard seismic vibration sensor mounted within the system enclosure.

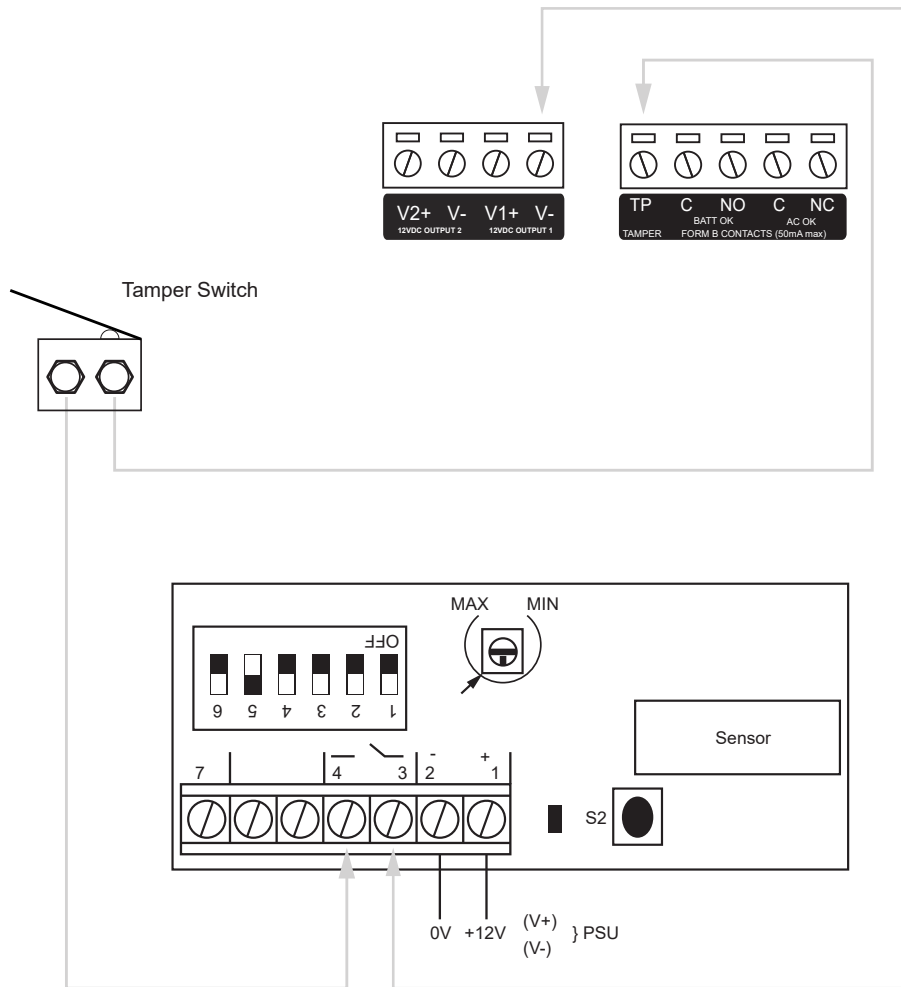

Connection

- Terminals **1(V+)** and **2(V-)**. 12V power connection, reverse polarity protected.
- Terminals **3 and 4**. N.C. alarm output contacts, with built in 10 ohm resistor in series.

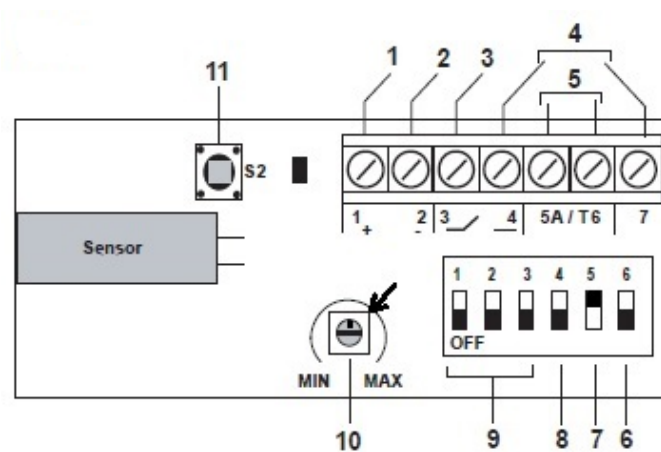

1. 12V (Screw terminal 1).
2. 0V (Screw terminal 2).
3. Alarm circuit. N/C contact. (Screw terminals 3&4).
4. Latch terminal (12V SET + SW +). Not used.
5. Anti-tamper. Terminals not used.
6. Not used. Off.
7. Sensitivity selection level (Low/High). Switch 5 set to on. High selected.
8. Latch reset switch. Not used. Off.
9. Pulse count selection switches. Not used. Off.
10. Sensitivity adjustment potentiometer.

Set pointer marker to point at the corner opposite the MIN marker.

11. Case anti-tamper switch. Not used.

Modes of Operation

When using the sensor in momentary mode it will be necessary to connect using a 4 core cable.

- The N.C. alarm contacts are non-latching.
- Upon alarm activation the alarm contacts will open circuit momentarily for a minimum time of 1 second before automatically resetting.
- The LED will illuminate when the alarm contacts are open circuit in response to an input signal.
- LED indication: During the sensitivity test procedure indication of the **green** LED denotes alarm and relay operation. Indication of the **red** LED denotes vibration detected (pulse) but insufficient to create alarm conditions.
- Dual stage linear sensitivity: The detector permits the installer a greater threshold of sensitivity adjustment by adjustment of the potentiometer through either a low level or high level adjustment.
- When DIP Switch 5 is in the ON position the sensitivity potentiometer allows adjustment in the high sensitivity area and when in the OFF position allows adjustment in the low sensitivity area.

Installation Procedure

1. Select the intended position for installation, ideally positioned horizontally in the vertical center of the enclosure, 50mm to the right of the large opening.

Ensure the surface is clean and clear of any irregularities.

2. Remove the sensor cover by unscrewing the single captive screw until the cover can easily be removed from the base.
3. Carefully lift the printed circuit board from the base.
4. Position the base in the mounting position and mark the desired fixing holes (3.1mm drill).
5. If rear cable entry is required, cables should be threaded through the rear of the base.
6. Fix the base in position using M3 pan head machine screws to the captive nuts provided in the enclosure, or with nuts and washers if located in an alternative position.

Take care not to let the screw protrude further than the nut height on the rear of the enclosure.

7. Carefully push the printed circuit board onto the base.
8. Make the electrical connections to the Shockgard SS-102, wired in series with the enclosure tamper switch 24HR monitor.
9. If side cable entry is being used, remove the appropriate knockout from the cover and insert a grommet.

10. Setting up and adjustment:

- With the unit in momentary operation (See Modes of Operation: Dual stage linear sensitivity above), use a terminal screwdriver to turn the sensitivity control fully clockwise to maximum (Position 6).
- Using a suitable implement, bang or tap the protected area, observing the LED response.
- Reduce the sensitivity by a small amount (turn sensitivity control anti-clockwise) and bang or tap the protected area.
- Repeat this process until the unit only just responds to the desired impact.

11. Replace the sensor cover, tighten the fixing screw and check its response to the desired impact.

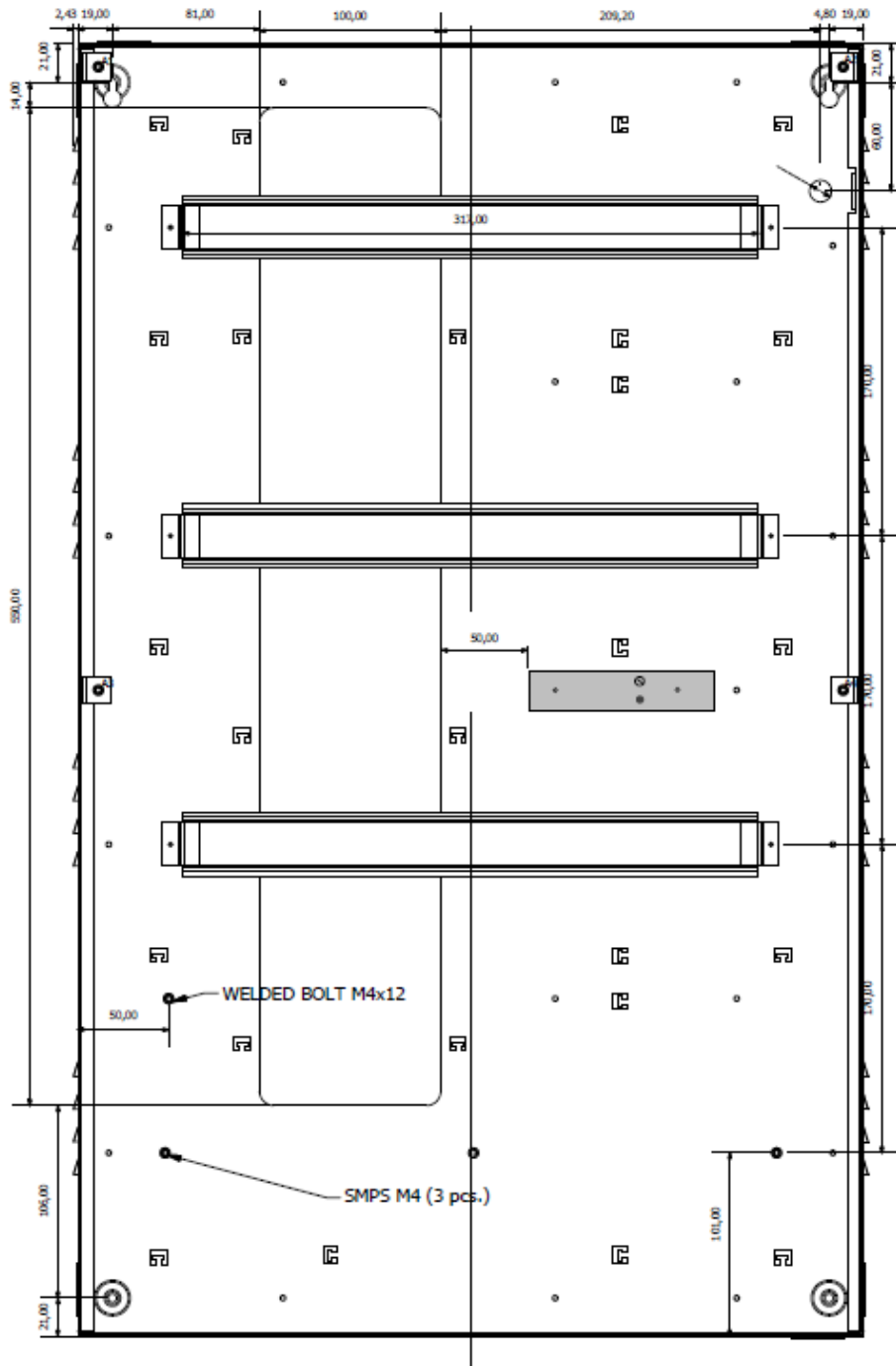

Wiring Diagram

CAUTION: Incorrect wiring may result in damage to the unit.

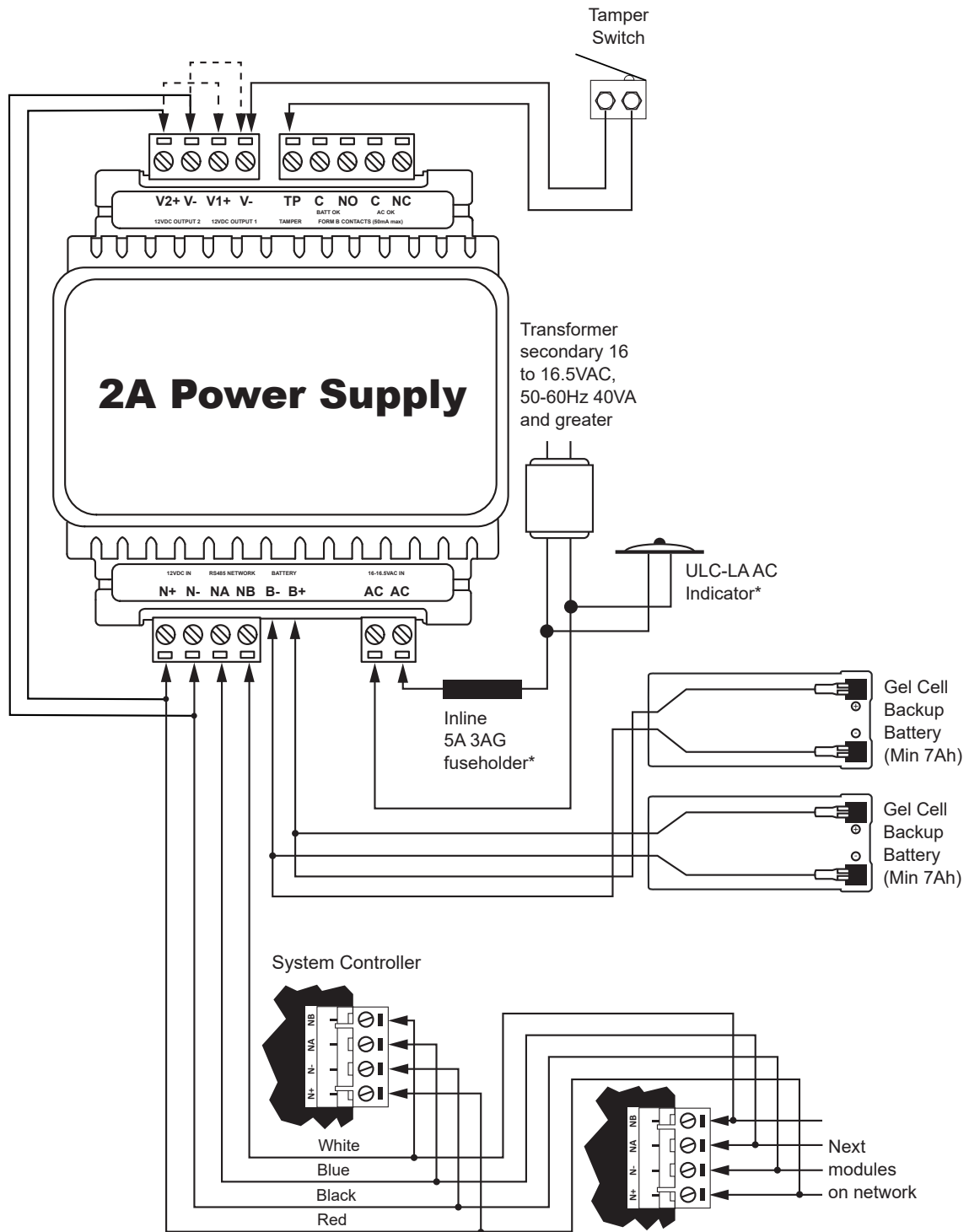

AC Power Supply

The power supply should be supplied by a dedicated electrical power source rated for a minimum 10A load and have a dedicated circuit breaker. Do not use a switch controlled breaker or a switched electrical point to supply electrical power. Connect the primary of a 16 to 16.5 VAC, 50-60Hz, 40VA or greater transformer to the electrical circuit and run the secondary to the AC input on the power supply terminals.

AC Power Connection

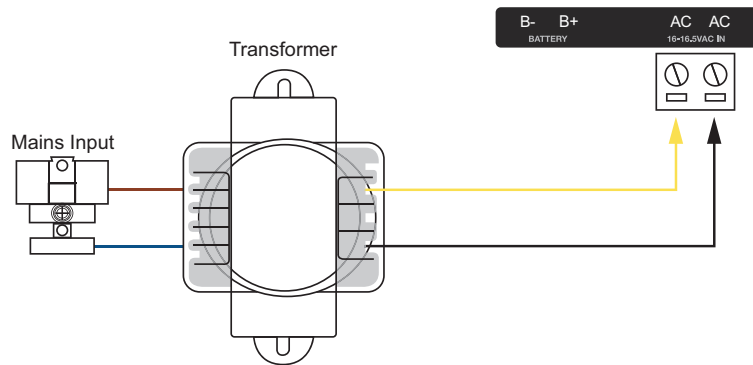

Specific regional regulations may allow the transformer to be mounted inside the cabinet enclosure. In this case wire the electrical circuit to the electrical termination point inside the cabinet enclosure and the secondary wires of the transformer to the AC input on the power supply. The earth wire shall be routed to the V- terminal on the power supply when using an internal transformer.

Warning:

- This installation should be made by qualified service personnel and should conform to all local codes.
- Termination of wiring to the power supply while power is applied or the battery is connected may cause serious damage to the power supply and will **VOID ALL WARRANTIES OR GUARANTEES**. Power the unit only after all wiring, configuration and jumper settings are completed.
- Extra care must be taken when wiring the AC inputs. Improper connection will cause permanent damage to the power supply.

Backup Battery

A battery backup must be connected to the module network to provide a monitored supply. The battery plays an important role in power conditioning and provides a continuous source of power in the event of a power outage.

Note: The power supply will not detect the backup battery if the power supply is off when the backup battery is connected. The power supply must be on when the backup battery is connected to detect its presence.

It is recommended that a minimum of a 7Ah battery is used as the main backup battery.



For UL/ULC installations the following battery specifications must be observed.

- Battery Type to be used: VRLA (valve regulated sealed lead acid type rechargeable battery)
- Recommended Battery: Yuasa model: NP7-12, 12V, 7Ah (www.yuasabatteries.com)
- Nominal Voltage: 12V
- Nominal Capacity: 7Ah
- Battery Maintenance: It is recommended to replace the battery every 3-5 years.

Connecting the Battery

From the accessory bag provided:

1. Connect the **red** and **black** battery termination wires to the B+ and B- plugs.
2. Connect the spade terminals to the battery as shown below.

Connection of the battery in reverse will not damage the power supply, but will cause the battery circuit to disconnect until correct connection is made.



Please refer to the section on Maximum Total Output Current: UL and ULC Installations for specific requirements on complying with UL and ULC installation standards.

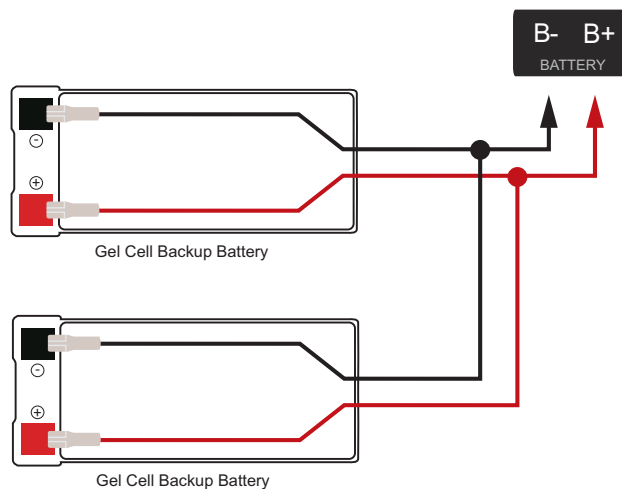

Warning:

- Only attach standard lead acid batteries.
- Do not connect the battery wires or B+ and B- plugs of the module to any other ancillary device (siren, lock, mag clamp, etc.).
- An incorrect connection may cause erroneous faults or serious damage to the module and will **VOID ALL WARRANTIES OR GUARANTEES.**

The battery test procedure uses a special algorithm to prevent deep discharge and increase battery endurance. A dynamic battery test is performed every ten minutes when mains power is present, and a battery condition alarm will be generated if the battery is either disconnected or shows poor capacity. Battery fault conditions will activate the battery trouble input associated with the address assigned to the power supply.

In addition to the dynamic battery test procedure, the power supply performs a battery presence test every 60 seconds, which determines whether the presence of a backup battery is detected. Similarly, if no backup battery is detected a battery condition alarm will be generated and the battery trouble input associated with the address assigned to the power supply will also be activated.

To comply with EN 50131-1 only one battery can be connected and monitored per system. If more capacity is required a single larger battery must be used.

Backup Battery Thresholds

The battery disconnection threshold is 8V. Upon reconnection of mains power the power supply automatically detects the backup battery and begins controlled charging at 500mA (typical).

Encrypted Module Network

The power supply incorporates encrypted RS-485 communications technology. Network power is supplied by the N+ and N- terminals. Connection of the communications and network power should be performed according to the diagram shown. It is important that the N+ network communications power be 12VDC supplied from an independent battery backed power supply unit or a networked module capable of supplying the required voltage to all devices on the RS-485 network.

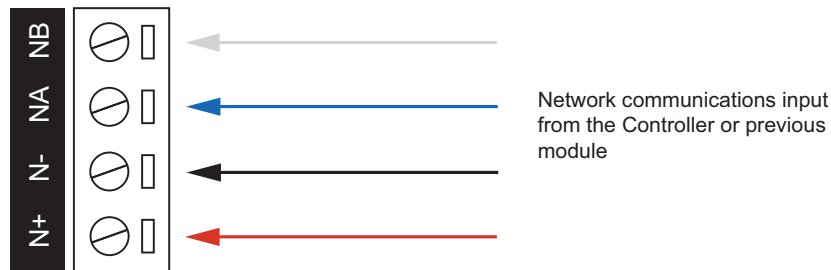

Always connect the power supply NA and NB terminals to the NA and NB terminals of the communication network.

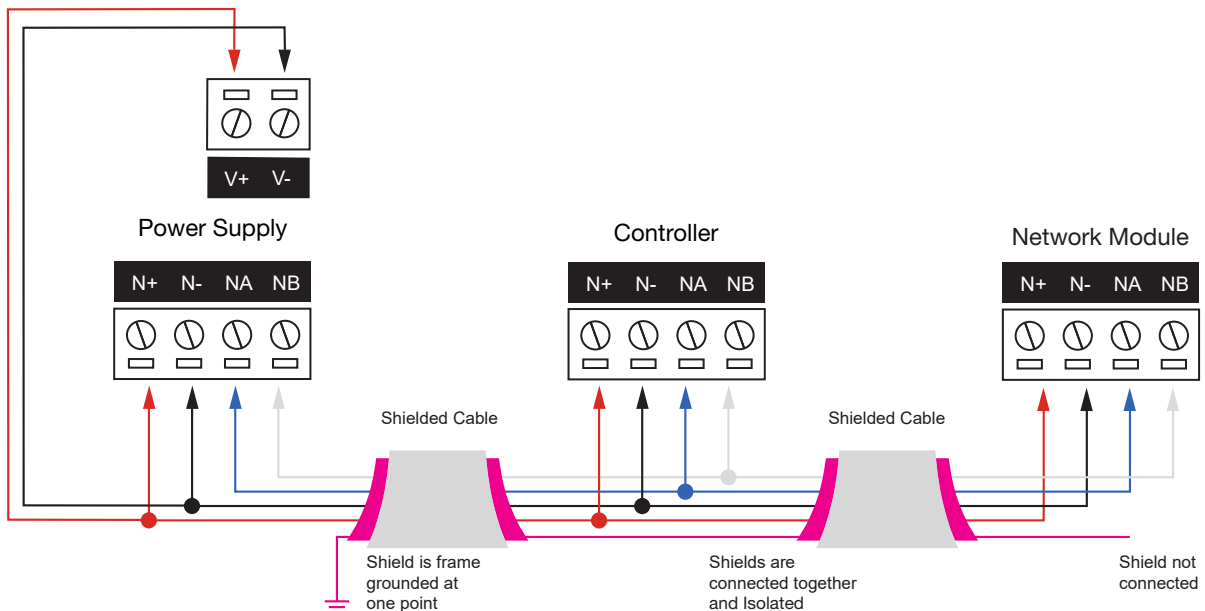

The diagram above shows how a single power supply can be connected to supply the module network. This connection is suitable for smaller systems, provided that the following values are all lower than or equal to the values outlined in the Technical Specifications section of this manual:

- Maximum total output current,
- AUX DC output current,
- Controller bell DC output current, and
- Total combined current

If any of these currents are exceeded, a separate power supply must be used, as shown below.

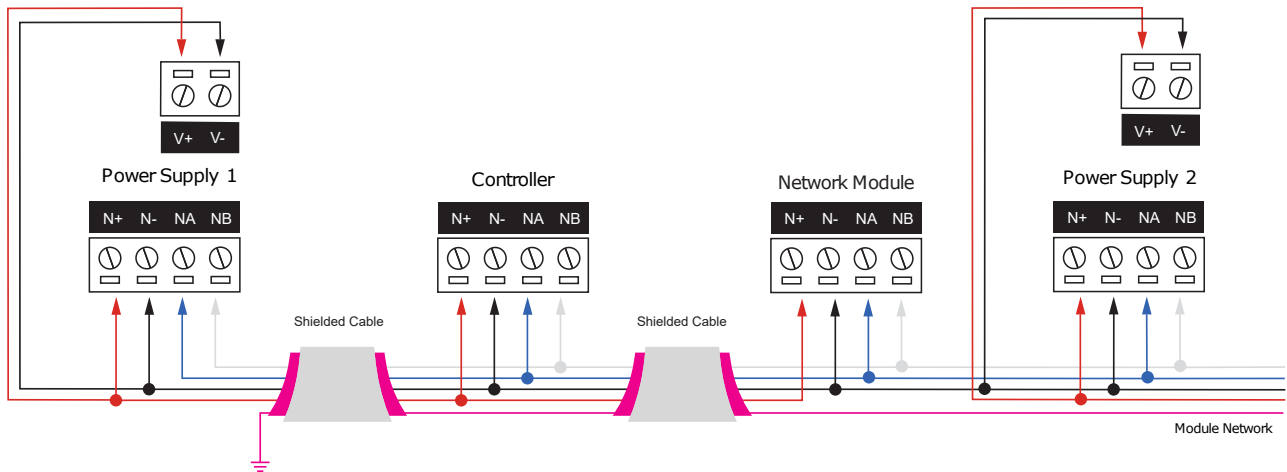

The 12V N+ and N- communication input must be supplied from only **one** point. Connections from more than one 12V supply may cause failure or damage to the unit or the device supplying network power.

Module Wiring

The recommended module network wiring specifications are:

- Belden 9842 or equivalent
- 24AWG twisted pair with characteristic impedance of 120 ohm
- Maximum total length of cable is 900m (3000ft)
- CAT5e / CAT6 are also supported for data transmission when using ground in the same cable (to a maximum length of 100m (328ft))

Warning: Unused wires in the cable must not be used to carry power to other devices.

End of Line (EOL) Resistors

The 330 ohm EOL (End of Line) resistor provided in the accessory bag **must** be inserted between the NA and NB terminals of the **first** and **last** modules on the RS-485 network. These are the modules physically located at the ends of the RS-485 network cabling.

First Module on RS-485 Network

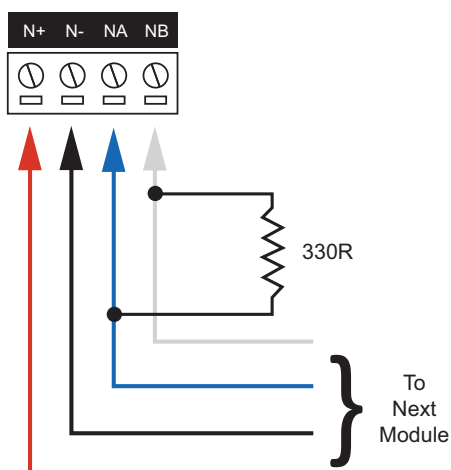

Last Module on RS-485 Network

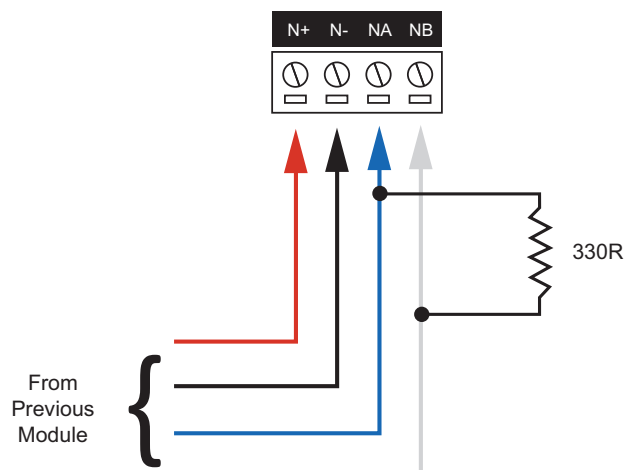

Output Load Connection

The power supply provides two sets of 12VDC output terminals, V1+ and V2+. Both V1+ and V2+ outputs are individually fused.

A maximum current output of 1.0 amps at 12VDC can be provided across each output at any one time. However, if a single current output of 2.0 amps is required, then both outputs need to be connected together in parallel.

When any inductive load, including electric locking devices, is powered (directly or indirectly) by the power supply a reverse EMF protection diode must be placed across the positive (V1+ or V2+) and negative (V-) terminals at the device.

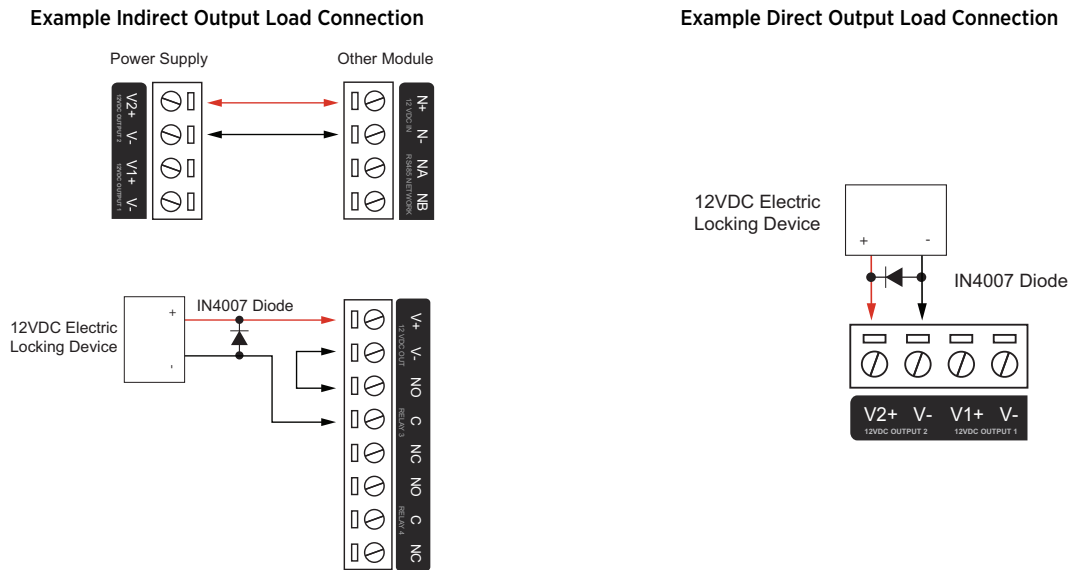

Note: The 1N4007 diode shown **must** be installed across the + and - terminals of any inductive load such as electric locks, magnetic or motorized devices.

Output Current Influence on Output Load Operation

The table below helps illustrate how the total output current drawn from the power supply module influences the operation of V1 and V2 outputs.

Output Load Operation Status	Output Load Current		
	0 - 2.0A	2.0 - 2.5A	2.5A - Short Circuit
Outputs Enabled (Mains Power)	✓	✓	
Outputs Supplied by Battery	✓	✓	
Output Over-Current Failure Trouble Input Activated		✓	✓
Over-Current Output Shutdown Activated			✓

Core Temperature on Output Load Operation

The table below helps illustrate how the core temperature of the power supply module influences the operation of the V1 and V2 outputs.

Output Load Operation Status	Core Temperature		
	<70°C	70-80°C	>80°C
Outputs Enabled (Mains Power)	✓	✓	
Outputs Supplied by Battery	✓	✓	✓
Output Over-Current Failure Trouble Input Activated		✓	✓
Over-Current Output Shutdown Activated			✓

Inputs

The power supply has no physical input connections.

Trouble Inputs

Each power supply can monitor up to 8 trouble inputs.

Trouble inputs are used to monitor the module status and in most cases are not physically connected to an external input.

The following table details the trouble inputs that are configured in the system and the trouble groups that they are associated with.

Input Number	Description	Default Trouble Group	Default Trouble Group Option
AExxx:01	Module Tamper	System	System Tamper
AExxx:02	Mains Failure	General	Power Fault
AExxx:03	Low Battery/Battery Failure	General	Power Fault
AExxx:04	Output Voltage Low	General	Power Fault
AExxx:05	Output Over-Current Failure	General	Power Fault
AExxx:06	Core Temperature Over-Temp Failure	General	Power Fault
AExxx:07	Reserved	None	None
AExxx:08	Module Offline	System	Module Offline

Replace 'xxx' with the appropriate address of the module that you are programming.

The power supply emulates an analog expander module on the Protege module network. This means that all programming, trouble input and output information is stored in and reported by the analog expander records when programming via a Protege keypad or Protege software.

Outputs

The power supply has two 50mA outputs that can operate as either programmable outputs or as predefined status outputs, depending on the network status of the module on the Protege system.

Online Mode

Upon successfully completing the initial registration with any Protege system controller, the outputs of the power supply operate in **online mode**. The module will then continue to operate in online mode until a firmware update is carried out. While in online mode the two outputs function as **programmable outputs** and can be used to activate bell sirens, lighting circuits, door locks, relay accessory products and other automation points.

Programmable Outputs

The 2 programmable outputs each have a solid-state relay. The connection example below shows the control of an external LED indicator.

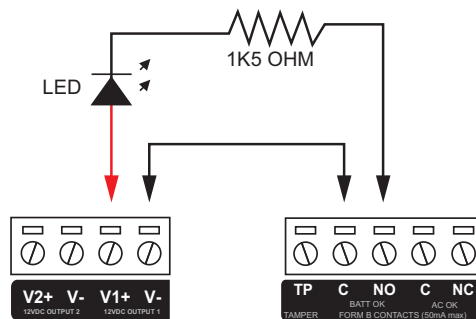

Warning: Switching inductive loads that can produce high back EMF voltages or large voltage-induced spikes can cause the module to behave unexpectedly and should be avoided. A suitable isolation circuit must be installed between the relay contacts of the module and the inductive load.

These outputs are rated for low power use only (50mA, 12V Max). Incorrect use may cause erroneous faults or serious damage to the power supply and will **VOID ALL WARRANTIES OR GUARANTEES**.

Offline Mode

Until connection to a Protege system controller is established, the outputs of the power supply operate in **offline mode**. While in offline mode the two outputs function as **status outputs**. In addition to the comprehensive front panel diagnostic indicators, these status outputs offer additional information that can aid the installer in diagnosing faults and conditions.

AC Fail Status Output

The AC fail status output has a solid-state relay. The output relay contacts disconnect (normally open) when AC power is removed and the unit remains running on backup battery power. Upon restoring AC power the output relay will revert back to its default state (normally closed).

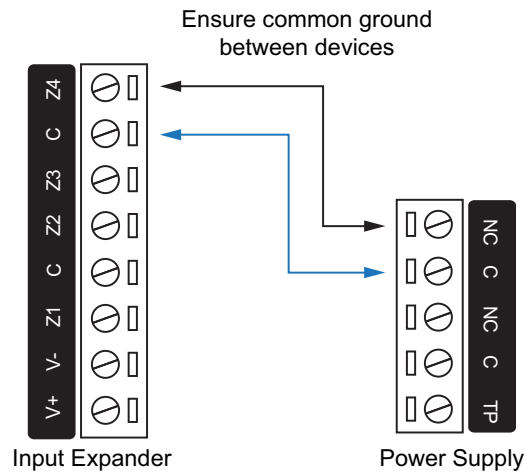

This output is suited for connection to an input on a Protege module with spare inputs available so that the power supply AC status can be externally monitored. The connection example above shows monitoring of the AC status set up in conjunction with a Protege input expander.

Battery Fail Status Output

The battery fail status output has a solid-state relay. The output relay contacts connect (normally closed) when either the backup battery has been disconnected, or when the power supply is running on backup battery power without AC power and the backup battery voltage drops below 11.2V. Upon reconnecting a backup battery with a voltage greater than 12.5V, the output relay will revert back to its default state (normally open).

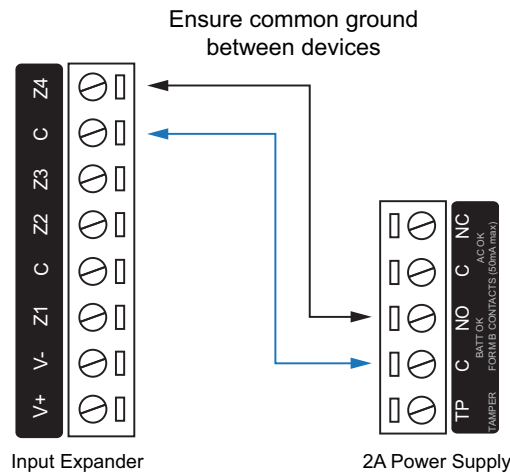

This output is suited for connection to an input on the Protege system for early detection of complete power failure. The connection example above shows monitoring of the battery status set up in conjunction with a Protege input expander.

The outputs used for both the AC fail and battery fail status outputs are rated for low power use only (50mA, 12V Max). Incorrect use may cause erroneous faults or serious damage to the Power Supply and will **VOID ALL WARRANTIES OR GUARANTEES**.

Intelligent Monitoring

The power supply is able to relay information about critical system voltages, currents and temperature to the Protege GX controller by registering as an analog expander module on the Protege network. The controller can then store these values in variables that can be viewed live from the Protege GX interface.

This feature is not available in Protege WX.

Monitoring Setup

The power supply will register with the Protege Controller as an analog expander module, AExxx.

The channels for each power supply will monitor:

- Channel 1: Voltage at V1+ output
- Channel 2: Voltage at V2+ output
- Channel 3: Battery voltage
- Channel 4: Total current output

Each channel can be associated with a data value and each data value assigned to a variable. These variables can then be monitored on a status page or floor plan.

The **Log Channel Data** option may also be selected to view the raw data as it is received in the event log. However, this will create a large number of events and should only be used for verifying the reception of data.

For more information on programming this feature, see the Protege GX Operator Manual.

Address Configuration

The module address is configured via programming and will require knowledge of the module serial number. The serial number can be found on the identification sticker on the product.

Refer to the Protege system controller configuration guide for address programming details.

The controller has a set limit on the number of modules of each type that it can support. When adding and configuring modules always refer to the Maximum Module Addresses table in the controller configuration guide.

LED Indicators

Protege DIN rail modules feature comprehensive diagnostic indicators that can aid the installer in diagnosing faults and conditions. In some cases an indicator may have multiple meanings depending on the status indicator display at the time.

Status Indicator

The status indicator displays the module status.

State	Description
Fast flash (green)	Module attempting registration with controller
Slow flash (green)	Module successfully registered with controller
Flashing (red)	Module communications activity

When the fault and status indicators are flashing alternately, the module is in identification mode, enabling the installer to easily identify the module in question. Upon either a module update or the identification time period expiring, the module will return to normal operation.

Fault Indicator

The fault indicator is lit any time the module is operating in non-standard mode. If the fault indicator is flashing, the module requires a firmware update or is in firmware update mode. When the fault indicator is on, the status indicator will flash an error code.

State	Description
Continuous slow flash (red)	Module is in boot mode awaiting firmware update
Constantly on (red)	Module is in error state and will flash an error code with the status indicator

Power Indicator

The power indicator is lit whenever the correct module input voltage is applied across the low voltage AC input terminals.

State	Description
Constantly on	Correct module input voltage applied
Constantly off	Incorrect module input voltage applied

V1 Output/V2 Output Indicators

The V1 output and V2 output indicators shows the status of the 12VDC output.

State	Description
Constantly on	12VDC output operating OK
Constantly off	12VDC output failure

Battery Indicator

The battery indicator shows the status of the backup battery.

State	Description (with mains power connected - power indicator on)
Flashing (red)	Backup battery is disconnected
On (red)	Backup battery failed its dynamic battery test
On (green)	Last backup battery dynamic test successful
State	Description (with mains power disconnected - power indicator off)
Flashing (red)	Mains has failed and the PSU is drawing power from the battery. State is Battery Low
Flashing (green)	Mains has failed and the PSU is drawing power from the battery. State is Battery Restore

Temp Indicator

The temp indicator will show the status of the unit's core temperature.

State	Description
On (red)	Core temperature exceeded. Over Temp Shutdown Activated
Flashing (red)	Core temperature within 15° C of over temp shutdown
On (green)	Core temperature OK

Over Current Indicator

The over current indicator will show the status of the output current for both V1+ and V2+.

State	Description
On (red)	Output current exceeded. Over Current Shutdown Activated
Off	Maximum output current not exceeded

Error Code Indication

When the module attempts to register or communicate with the system controller a registration error can be generated indicating that it was not successful.

Error Code Display

The following table is only valid if the **fault** indicator is constantly on and the **status** indicator is flashing red.

If the fault indicator is flashing the module requires a firmware update or is currently in firmware update mode.

The status indicator will flash red with the error code number. The error code number is shown with a 250ms on and off period (duty cycle) with a delay of 1.5 seconds between each display cycle.

Flash	Error Description
1	Unknown Error Code The error code returned by the system controller could not be understood by the module.
2	Firmware Version The firmware version on the module is not compatible with the system controller. To clear this error, update the module using the module update feature in the controller's web interface.
3	Address Too High The module address is above the maximum number available on the system controller. To clear this error change the address to one within the range set on the system controller, restart the module by disconnecting the power.
4	Address In Use The address is already in use by another module. To clear this error set the address to one that is not currently occupied. Use the view network status command to list the attached devices, or the network update command to refresh the registered device list.
5	Controller Secured Registration Not Allowed The controller is not accepting any module registrations. To allow module registrations use the network secure command to change the setting to not secured.
6	Serial Number Fault The serial number in the device is not valid. Return the unit to the distributor for replacement.
7	Locked Device The module or system controller is a locked device and cannot communicate on the network. Return the unit to the distributor for replacement.

Mechanical Diagram

The mechanical diagram shown below outlines the essential details needed to help ensure the correct installation of the power supply.

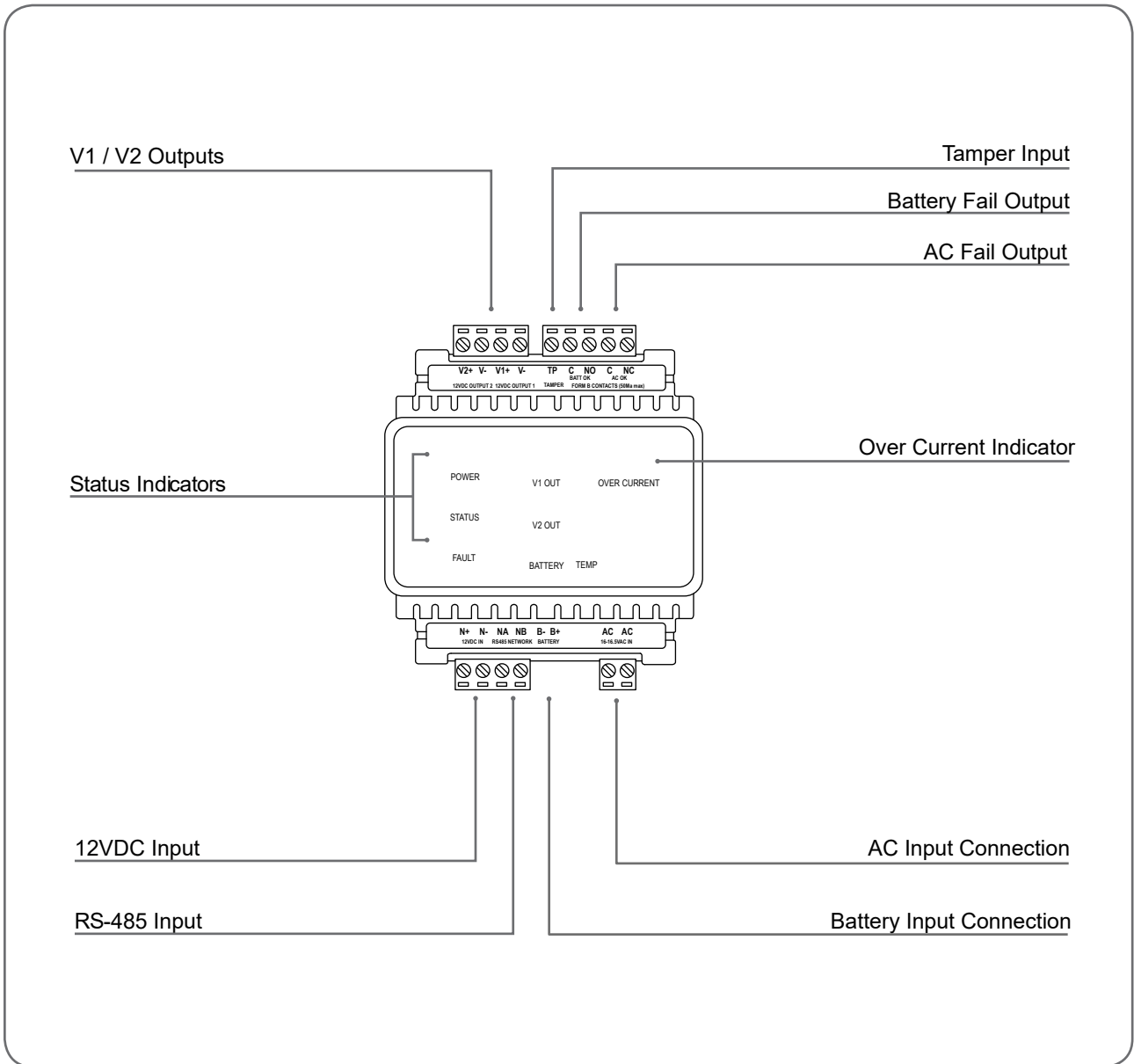

Mechanical Layout

The mechanical layout shown below outlines the essential details needed to help ensure correct installation and mounting. All measurements are shown in millimeters.

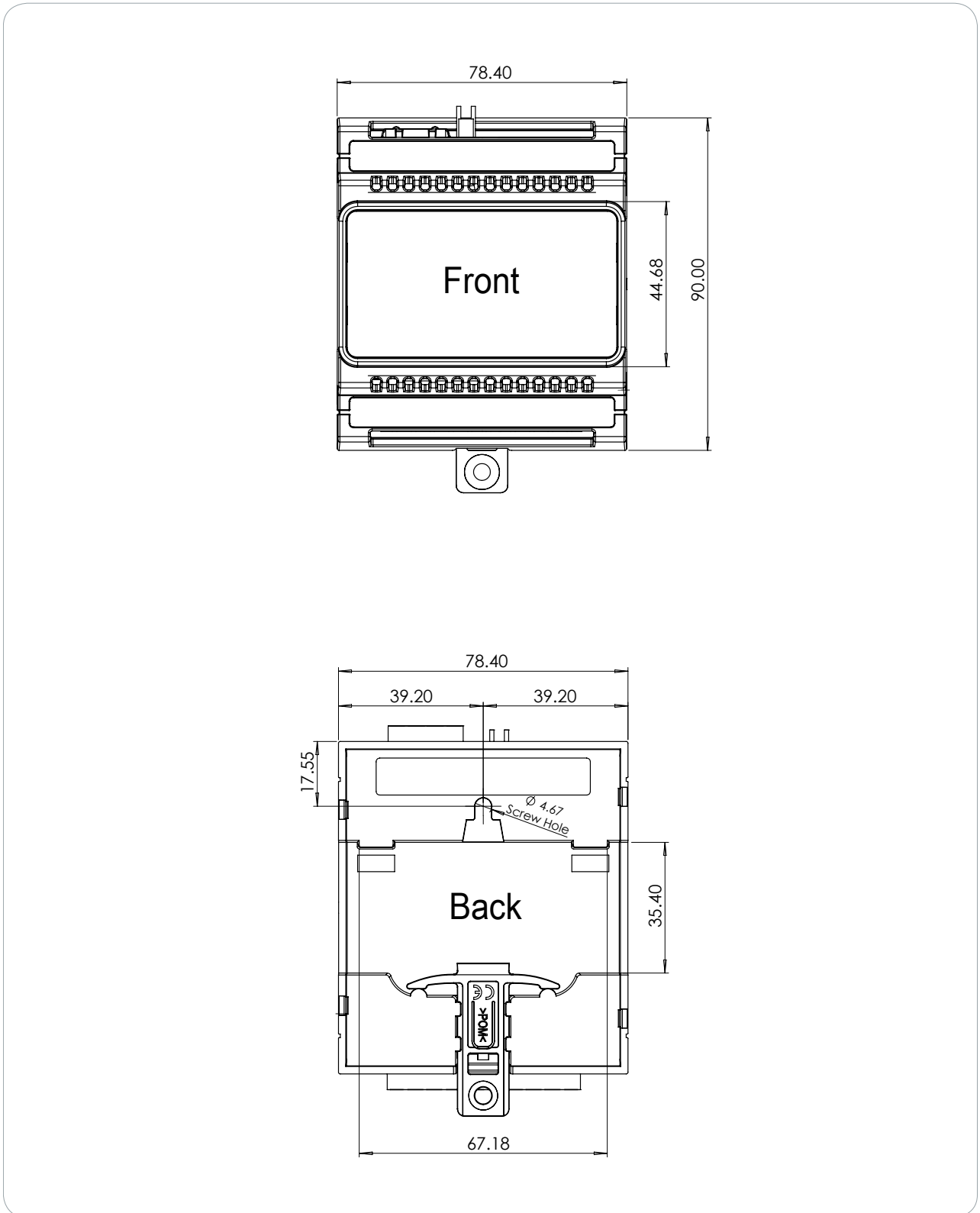

Technical Specifications

The following specifications are important and vital to the correct operation of this product. Failure to adhere to the specifications will result in any warranty or guarantee that was provided becoming null and void.

Ordering Information	
PRT-PSU-DIN-2A	Protege DIN Rail 2A Intelligent Power Supply
Power Supply	
AC Input Voltage	16 to 16.5VAC 50-60Hz
Operating AC Input Current	3.15A @ 16.5VAC when Total Combined Current = 2.5A 2.2A @ 16.5VAC when Total Combined Current = 1.7A
Operating Current	140mA (Typical)
Total Combined Current	1.7A (Max) using a 37/40VA transformer 2.5A (Max) using a 60VA or greater transformer Electronically limited at 2.5A
DC Output (Single)	12.4VDC, 1.0A (Typical) Electronic Shutdown at 1.85A
Battery Charging	350mA (Typical) *Additional to the 2A Combined DC Output
Battery Low	11.75VDC
Battery Restore	12.5VDC
Electronic Disconnection	9.4VDC
Communication	
RS-485	Isolated Module Network
Inputs	
Tamper	Dedicated Hardware Tamper Input
Trouble Inputs	8 (internal)
Outputs	
PGM Outputs	2 Solid-State Relay Outputs, 50mA 12V Max
Dimensions	
Dimensions (L x W x H)	78.4 x 90 x 60mm (3.08 x 3.54 x 2.36")
Net Weight	190g (6.7oz)
Gross Weight	280g (9.9oz)
Operating Conditions	
Operating Temperature	UL/ULC 0° to 49°C (32° to 120°F) : EU EN -10° to 55°C (14° to 131°F)
Storage Temperature	-10° to 85°C (14° to 185°F)
Humidity	0%-93% non-condensing, indoor use only (relative humidity)
Mean Time Between Failures (MTBF)	237,455 hours (calculated using RFD 2000 (UTE C 80-810) Standard)

It is important that the unit is installed in a dry cool location that is not affected by humidity. Do not locate the unit in air conditioning or a boiler room that can exceed the temperature or humidity specifications.

Integrated Control Technology continually strives to increase the performance of its products. As a result these specifications may change without notice. We recommend consulting our website (www.ict.co) for the latest documentation and product information.

Maximum Total Output Current: UL and ULC Installations

The following table describes the maximum total output current available for standby operation using an external VRLA battery in order to comply with UL and ULC standby requirements.

Application	Maximum Total Output Current Available	Minimum System in Standby	Maximum Charging Current (Mains present)	Battery Rating
UL 294 and CAN/ULC-S319, 4hr backup	2000mA	240mA	350mA	2 x 12VDC, 7Ah = 14Ah
CAN/ULC-S304 24hr backup	2000mA	180mA	350mA	2 x 12VDC, 7Ah = 14Ah
CAN/ULC-S559 24hr backup	2000mA	180mA	350mA	2 x 12VDC, 7Ah = 14Ah
UL 1610, UL 1635 4hr backup	2000mA	240mA	350mA	2 x 12VDC, 7Ah = 14Ah
UL 1610, UL 1635 24hr backup	2000mA	180mA	350mA	2 x 12VDC, 7Ah = 14Ah
UL 1610, UL 1635 72hr backup	2000mA	180mA	350mA	2 x 12VDC, 7Ah = 14Ah

The Maximum Total Output Current Available is the **maximum** current that can be supplied to the auxiliary and bell DC Outputs.

These are the maximum current values to ensure compliance with the standby requirements.

New Zealand and Australia

General Product Statement

The RCM compliance label indicates that the supplier of the device asserts that it complies with all applicable standards.



European Standards

CE Statement

Conforms where applicable to European Union (EU) Low Voltage Directive (LVD) 2014/35/EU, Electromagnetic Compatibility (EMC) Directive 2014/30/EU, Radio Equipment Directive (RED) 2014/53/EU and RoHS Recast (RoHS2) Directive: 2011/65/EU + Amendment Directive (EU) 2015/863.

This equipment complies with the rules, of the Official Journal of the European Union, for governing the Self Declaration of the CE Marking for the European Union as specified in the above directive(s).



Information on Disposal for Users of Waste Electrical & Electronic Equipment

This symbol on the product(s) and / or accompanying documents means that used electrical and electronic products should not be mixed with general household waste. For proper treatment, recovery and recycling, please take this product(s) to designated collection points where it will be accepted free of charge.

Alternatively, in some countries you may be able to return your products to your local retailer upon purchase of an equivalent new product.

Disposing of this product correctly will help save valuable resources and prevent any potential negative effects on human health and the environment, which could otherwise arise from inappropriate waste handling.

Please contact your local authority for further details of your nearest designated collection point.

Penalties may be applicable for incorrect disposal of this waste, in accordance with your national legislation.

For business users in the European Union

If you wish to discard electrical and electronic equipment, please contact your dealer or supplier for further information.

Information on Disposal in other Countries outside the European Union

This symbol is only valid in the European Union. If you wish to discard this product please contact your local authorities or dealer and ask for the correct method of disposal.

EN50131 Standards

This component meets the requirements and conditions for full compliance with EN50131 series of standards for equipment classification.

EN 50131-1:2006+A2:2017, EN 50131-3:2009, EN 50131-6:2008+A1:2014, EN 50131-10:2014, EN 50136-1:2012, EN 50136-2:2013, EN 60839-11-1:2013

Security Grade 4

Environmental Class II

Equipment Class: Fixed

Readers Environmental Class: IVA, IK07

SP1 (PSTN – voice protocol)

SP2 (PSTN – digital protocol)

SP6 (LAN – Ethernet) and DP1 (LAN – Ethernet + PSTN)

SP6 (LAN – Ethernet) and DP1 (LAN – Ethernet + USB-4G modem)

Tests EMC (operational) according to EN 55032:2015

Radiated disturbance EN 55032:2015

Power frequency magnetic field immunity tests (EN 61000-4-8)

Power Supply Type A (EN 50130-4 ed. 2)

Mains supply voltage variations (EN 50130-4 ed. 2)

Mains supply voltage dips and short interruption (EN 50130-4 ed. 2, EN 61000-4-2 ed. 2)

Electrostatic discharge (EN 50130-4 ed. 2, EN 61000-4-2 ed. 2)

Contact discharges ± 6 kV, Air discharges to ± 8 kV

Radiated electromagnetic fields (EN 50130-4 ed. 2, EN 61000-4-3 ed.3)

Conducted disturbances induced by electromagnetic fields (EN 50130-4 ed. 2, EN 61000-4-6)

Fast Transient bursts (EN 50130-4 ed. 2, EN 61000-4-4 ed.2)

To the AC mains supply lines applied disturbance signal voltage level 2 kV both polarities for 1 minute. To other supply / signal lines applied by the capacitive clamp injection method disturbance signal voltage level 1 kV for both polarities for 1 minute.

Slow high energy voltage surge (EN 50130-4 ed. 2, EN 61000-4-5 ed.2)

To comply with EN 50131-1, EN 60839-11 Security Grade 4 and AS/NZS2201.1 class 4&5 Vibration Detection for PreTamper Alarm, protection is provided by a DSC SS-102 Shockgard Seismic vibration sensor mounted within the system enclosure. Alarm output is provided by a pair of non-latching, N.C. (normally closed) relay contacts, opening for a minimum of 1 second on detection of an alarm connected in series with the 24Hr tamper input (TP) on the PSU (or any other system input designated/programmed as a 24Hr Tamper Alarm).

This relay is normally energized to give fail-safe operation in the event of a power loss. Indication of detection is provided by a LED situated on the front cover. The vibration sensor is fully protected from tampering by a N.C. micro switch operated by removal of the cover.

Enclosure EN-DIN-24 has been tested and certified to EN50131.

By design, the enclosures for all Integrated Control Technology products, EN-DIN-11, EN-DIN-12 and EN-DIN-24-ATTACK, comply with the EN 50131 standards. Tamper protection against removal of the cover as well as removal from mounting is provided by tamper switch.

Warning: Enclosures supplied by 3rd parties may not be EN50131-compliant, and should not be claimed as such.

To comply with EN 50131-1 only one battery can be connected and monitored per system. If more capacity is required a single larger battery must be used.

UK Conformity Assessment Mark

General Product Statement

The UKCA Compliance Label indicates that the supplier of the device asserts that it complies with all applicable standards.



UL and ULC Installation Requirements

Only UL / ULC listed compatible products are intended to be connected to a UL / ULC listed control system.

UL/ULC Installation Cabinet Options

ULC Central Station Fire Monitoring, UL/ULC Central Station Alarm Installations

Cabinet Model	UL/ULC Installation Listings
EN-DIN-24-ATTACK	UL1610, UL1635, UL1076, ULC-S304, ULC-S559

ULC Fire Monitoring

Cabinet Model	ULC Installation Listings
EN-DIN-12	ULC-S559
EN-DIN-24	
EN-DIN-24-ATTACK	
EN-DIN-11V	

Electronic Access Control System Installations

Cabinet Model	UL/ULC Installation Listings
EN-DIN-12	UL294, UL1076, ULC-ORD-C1076-86, CAN/ULC-S319
EN-DIN-24	
EN-DIN-24-ATTACK	



All cabinet installations of this type must be located **inside the Protected Area**.

Not to be mounted on the exterior of a vault, safe or stockroom.

All cabinet internal covers and lids/doors must be connected to the cabinet's main ground point for electrical safety and static discharge protection.

ULC Compliance Requirements

CAN/ULC-60839-11-1

- The Protege controller and reader expander module are intended to be mounted within the enclosure (refer to UL/ULC Installation Cabinet Options), installed inside the protected premise, and are CAN/ULC-60839-11-1 Listed for Class I applications only.
- Exit devices and wiring must be installed within the protected area.
- For the Protege controller and reader expander module, all RS-485 and reader terminal connections must be made using shielded grounded cable.
- All readers must be connected with shielded, grounded cable.

- A bell or visual indicator used as an arming acknowledgment signal must be listed to a ULC security, signaling or fire standard. If intended to be mounted outside, it must be rated for outdoor use.
- Fail secure locking mechanisms shall only be installed where allowed by the local authority having jurisdiction (AHJ) and shall not impair the operation of panic hardware and emergency egress.
- If fire resistance is required for door assembly, portal locking device(s) must be evaluated to ULC-S533 and CAN/ULC-S104.
- Must be installed with CAN/ULC-60839-11-1 listed portal locking device(s) for ULC installations.
- If a flexible cord is used to connect to line voltage, strain relief must be provided for the cord inside the enclosure or at the knockout.
- The power supply is not intended to be mounted on the exterior of vault, safe, or stockroom.
- **Hardwire Transformer Marcus M4758CT**
When installed with the power supply manufactured by Marcus, Model M4758CT, the Littelfuse Part No. 150322 fuseholder and Littelfuse Part No. 0312005 5A, 3AG fast-acting fuse must be installed in-line to the Power Supply.

CAN/ULC-S304

- **Auto Arming**

Control units that support auto arming shall provide an audible signal throughout the protected area not less than 10 min prior to the auto arming taking place. The control unit shall allow authorized users to cancel the auto arming sequence and transmit such cancelation to the signal receiving center with the identification of the authorized user that canceled the action.

The following options must be enabled in the Protege system when using the Auto Arming feature. When the defer warning time is programmed to 10 minutes, the output group will be activated 10 minutes before the system performs the Auto Arming in the associated Area.

- The **Defer Output or Output Group** must be programmed. Refer to the section Areas | Outputs in the Operator Reference Manual for programming instructions.
- The **Defer Warning Time** must be programmed to not less than 10 minutes. Refer to the section Areas | Configuration in the Operator Reference Manual.
- The **Defer Automatic Arming** option must be enabled. Refer to the section Areas | Options (2) in the Operator Reference Manual.

- **Arming Signal**

A bell or visual indicator used as an arming acknowledgment signal must be listed to a ULC security, signaling or fire standard. If intended to be mounted outside, it must be rated for outdoor use.

- **Double EOL Input Configuration**

Only double EOL Input Configuration shall be used. Refer to the Inputs section of this manual and the section Inputs | Options in the Operator Reference Manual.

- **Multiplex System and Poll Time**

The Protege controller is compatible with the ArmorIP Internet Monitoring Receiver. Poll Time must be set to 40 seconds and the Grace Time must be set to 20 seconds.

In the Protege system, the reporting service must be configured to 40 seconds. The following options are required for the service selected as Report IP type:

- The **Log Polling Message** option must be enabled. Refer to the section Report IP | Options in the Operator Reference Manual.
- The **Poll Time** must be programmed to 40 seconds. Refer to the Report IP | General section in the Operator Reference Manual.

- **Central Station Signal Receiver**

The common equipment of each signal receiving center control unit shall be limited to 1000 alarm systems.

- **Number of attempts**

In the event of unsuccessful communication, a digital alarm communicator transmitter shall make a minimum of 5 and a maximum of 10 attempts. Where the maximum number of attempts to complete the sequence is reached, an indication of the failure shall be made at the premises.

In the Protege system, the reporting service selected as Contact ID must have the number of attempts programmed to 5 attempts. The **Dial Attempts** option must be programmed. Refer to the section Contact ID | Settings in the Operator Reference Manual.

If the PRT-4G-USB cellular modem is being used as the secondary reporting option in the installation, the Report IP service assigned to the cellular modem must be programmed as above.

- **Check-In Time**

DACT communication channel check-in time is not to exceed 24 hrs.

- **Trouble Input Service Test Report**

- The **Test Report Time** must be programmed. Refer to the section Controllers | Configuration in the Operator Reference Manual.
- The **Generate Input Restore on Test Input** option must be enabled. Refer to the section Controller | Options in the Operator Reference Manual.
- The **Test Report Time is Periodic** option must be enabled. Refer to the section Controller | Options in the Operator Reference Manual.

- **Primary Communication Channel**

The first attempt to send a status change signal shall utilize the primary communication channel.

The Report IP and Contact ID services must be programmed and enabled within the Protege system, and the CID service must be set as the backup service.

If the PRT-4G-USB cellular modem option is being used as the secondary reporting option in the installation, the Report IP service assigned to the cellular modem must be configured as the backup service.

The following options are required:

- The **Contact ID Reporting Service** must be enabled and the **Service Mode** must be configured to start with the operating system.
- Refer to the section Contact ID in the Operator Reference Manual.
- The **Report IP Service** must be enabled as the primary communication channel and the **Service Mode** must be configured to start with the operating system. The **Reporting Protocol** must be set to ArmorIP, and the **Backup Service** must be configured to use the Contact ID Service.

If the PRT-4G-USB cellular modem option is being used as the secondary reporting option in the installation, the **Backup Service** must be configured to use the Report IP service assigned to the cellular modem.

- Refer to the section Report IP in the Operator Reference Manual.
- All ULC S304 P3 applications must transmit signals simultaneously over both the primary communications channel and the Backup Service. This will occur automatically with the above programming.

- **Status Change Signal**

An attempt to send a status change signal shall utilize both primary and secondary communication channels.

- **Local Annunciation if Signal Reporting Failure**

Failure of the primary communication channel or secondary communication channel shall result in a trouble signal being transmitted to the signal receiving center within 240 seconds of the detection of the fault. Failure of either communication channel shall be annunciated locally within 180 seconds of the fault.

The following options must be enabled in the Protege system:

- The **Ethernet Link Failure** trouble input must be programmed.
- The **Trouble Input Area** must be armed. Refer to the section Trouble Inputs | Areas and Input Types in the Operator Reference Manual.
- The **Log Modem Events to Event Buffer** option must be selected in the backup reporting service.

- **Network and Domain Access**

Neither the subscriber control unit nor the signal receiving center receiver shall be susceptible to security breaches in general-purpose operating systems.

Network access policies should be set to restrict unauthorized network access and "spoofing" or "denial of service" attacks.

- **Ethernet Connections**

All ethernet network connections shall be installed within the same room as the equipment.

- **Encryption**

For active communications channel security, encryption shall be enabled at all times.

The ArmorIP-E (UDP) protocol must be used and the Encryption Type must be set to AES-256.

The following options must be enabled for the Report IP service in the Protege system.

- The **Reporting Protocol** must be set to ArmorIP (UDP) Encrypted. The AES key must be set as specified by monitoring station.
- Refer to the section Report IP | General in the Operator Reference Manual.

- **Server Configuration**

Where a server is employed for control over network addressing, encryption or re-transmission, such shall be designed to remain in the "on state" at all times.

Communicators are not suitable for active communication channel security and medium or high risk applications unless such can be "online" at all times, have a minimum 128 bit encryption scheme, have encryption enabled, network and domain security implemented.

Network access policies shall be set to restrict unauthorized network access and "spoofing" or "denial of service" attacks.

- **Internet Service Provider (ISP)**

The Internet Service Provider (ISP) providing service shall meet the following requirements:

- redundant servers/systems
- back-up power
- routers with firewalls enabled and
- methods to identify and protect against "Denial of Service" attacks (i.e. via "spoofing")

- **Information Technology Equipment, Products or Components of Products**

Products or components of products, which perform communications functions only, shall comply with the requirements applicable to communications equipment as specified in CAN/CSA-C22.2 No. 62368-1, Audio/video, information and communication technology equipment - Part 1: Safety requirements. Where network interfaces, such as the following, are internal to the subscriber control unit or receiver, compliance to CAN/CSA-C22.2 No. 62368-1 is adequate. Such components include, but are not limited to:

- A) Hubs;
- B) Routers;
- C) Network interface devices;
- D) Third-party communications service providers;
- E) Digital subscriber line (DSL) modems; and
- F) Cable modems.

- **Backup Power Requirements**

Power for network equipment such as hubs, switchers, routers, servers, modems, etc., shall be backed up or powered by an uninterruptible power supply (UPS), stand-by battery or the control unit, capable of facilitating 24h standby, compliant with Clauses 16.1.2 and 16.4.1 of CAN/ULC-S304.

For communications equipment employed at the protected premises or signal receiving center and intended to facilitate packet switched communications, as defined in CAN/ULC-S304, 24h back-up power is required.

- **Compromise Attempt Events**

ArmorIP detects the reception of any invalid packet on the programmed port as a potential system **compromise attempt**. Each compromise attempt sends a notification to the receiver, and logs a Compromise Attempt event under the Live Panel Events.

The event is sent with the following details:

- **Account Code** as defined in the Serial Receiver settings
- **Event Code** 0x163
- **Group Code** as defined in the Serial Receiver settings
- **Point Code** as defined in the Serial Receiver settings

Refer to the section [Global Settings | Serial Receiver](#) in the *ArmorIP Version 3 Internet Monitoring Application User Manual*.

For UL and ULC installations the Central Station Receiving software must have the Contact ID details as specified, programmed for the **Compromise Attempt** event.

- **Power Supply Mains Power Connection**

If a flexible cord is used to connect to line voltage, strain relief must be provided for the cord inside the enclosure or at the knockout.

The power supply is not intended to be mounted on the exterior of vault, safe, or stockroom.

- **Hardwire Transformer Marcus M4758CT**

When installed with the power supply manufactured by Marcus, Model M4758CT, the Littelfuse Part No. 150322 fuseholder and Littelfuse Part No. 0312005 5A, 3AG fast-acting fuse must be installed in-line to the Power Supply.

CAN/ULC-S319

- The Protege controller and reader expander module are intended to be mounted within the enclosure (refer to UL/ULC Installation Cabinet Options), installed inside the protected premise, and are CAN/ULC-S319 Listed for Class I applications only.
- Exit devices and wiring must be installed within the protected area.
- For the Protege controller and reader expander module, all RS-485 and reader terminal connections must be made using shielded grounded cable.
- All readers must be connected with shielded, grounded cable.
- A bell or visual indicator used as an arming acknowledgment signal must be listed to a ULC security, signaling or fire standard. If intended to be mounted outside, it must be rated for outdoor use.
- Fail secure locking mechanisms shall only be installed where allowed by the local authority having jurisdiction (AHJ) and shall not impair the operation of panic hardware and emergency egress.
- If fire resistance is required for door assembly, portal locking device(s) must be evaluated to ULC-S533 and CAN/ULC-S104.
- Must be installed with CAN/ULC-S319 listed portal locking device(s) for ULC installations.
- If a flexible cord is used to connect to line voltage, strain relief must be provided for the cord inside the enclosure or at the knockout.
- The power supply is not intended to be mounted on the exterior of vault, safe, or stockroom.

- **Hardwire Transformer Marcus M4758CT**

When installed with the power supply manufactured by Marcus, Model M4758CT, the Littelfuse Part No. 150322 fuseholder and Littelfuse Part No. 0312005 5A, 3AG fast-acting fuse must be installed in-line to the Power Supply.

CAN/ULC-S559

- **Signal Reporting**

Any fault of an active communication system shall be annunciated and recorded at the signal receiving center within 180 s of the occurrence of the fault.

The Report IP and Contact ID services must be programmed and enabled within the Protege system. The following options are required:

- The **Contact ID Reporting Service** must be enabled and the **Service Mode** must be configured to start with the operating system.
- Refer to the section [Contact ID](#) in the *Operator Reference Manual*.

- The **Report IP Service** must be enabled as the primary communication channel, the **Service Mode** must be configured to start with the operating system, and the **Reporting Protocol** must be set to ArmorIP.
- Refer to the section Report IP in the Operator Reference Manual.
- The **Trouble Area** must be armed. Refer to the section Trouble Inputs | Areas and Input Types in the Operator Reference Manual.

In the ArmorIP Internet Monitoring Software the **Poll Time** must be set to 40 seconds and the **Grace Time** must be set to 20 seconds. Refer to the section Poll/Grace Time in the ArmorIP Version 3 Internet Monitoring Application User Manual.

- **Central Station Signal Receiver**

The maximum number of signal transmitting units connected to any transmission channel shall conform to the manufacturer's recommendations. The ArmorIP Receiver supports up to 10000 simultaneous connections.

Refer to the section Internet Connections Requirements in the ArmorIP Receiver Installation Manual for further details.

- **Number of attempts**

In the event of unsuccessful communication, a digital alarm communicator transmitter shall make a minimum of 5 and a maximum of 10 attempts. Where the maximum number of attempts to complete the sequence is reached, an indication of the failure shall be made at the premises.

In the Protege system, the reporting service selected as Contact ID must have the number of attempts programmed to 5 attempts. The **Dialing Attempts** option must be programmed. Refer to the section Contact ID | Settings in the Operator Reference Manual.

If the PRT-4G-USB cellular modem is being used as the secondary reporting option in the installation, the Report IP service assigned to the cellular modem must be programmed as above.

- **Check-In Time**

DACT communication channel check-in time is not to exceed 24 hrs.

- **Trouble Input Service Test Report**

- The **Test Report Time** must be programmed. Refer to the section Controllers | Configuration in the Operator Reference Manual.
- The **Generate Input Restore on Test Input** option must be enabled. Refer to the section Controller | Options in the Operator Reference Manual.
- The **Test Report Time is Periodic** option must be enabled. Refer to the section Controller | Options in the Operator Reference Manual.

- **Ethernet Connections**

All ethernet network connections shall be installed within the same room as the equipment.

- **External Wiring**

All wiring extending outside of the enclosure must be protected by conduit.

- **Power Supply Mains Power Connection**

If a flexible cord is used to connect to line voltage, strain relief must be provided for the cord inside the enclosure or at the knockout.

The power supply is not intended to be mounted on the exterior of vault, safe, or stockroom.

- **Arming Signal**

A bell or visual indicator used as an arming acknowledgment signal must be listed to a ULC security, signaling or fire standard. If intended to be mounted outside, it must be rated for outdoor use.

- **Keypad Wiring**

The RS-485 connection to the keypad must be wired such that the shorts and other faults on the RS-485 line connection of the keypad will not cause the controller to malfunction.

- **Fire Areas**

Fire areas shall be separated from burglar areas through area partitioning.

NOTE: Any available dry relay contact on the Protege controller or output expander may be used for the FACP system, provided the selected output is programmed as the Report OK output.

- **Hardwire Transformer Marcus M4758CT**

When installed with the power supply manufactured by Marcus, Model M4758CT, the Littelfuse Part No. 150322 fuseholder and Littelfuse Part No. 0312005 5A, 3AG fast-acting fuse must be installed in-line to the Power Supply.

**CAN/ULC-S559
CONTROLLER
ACTIVE COMMUNICATION**

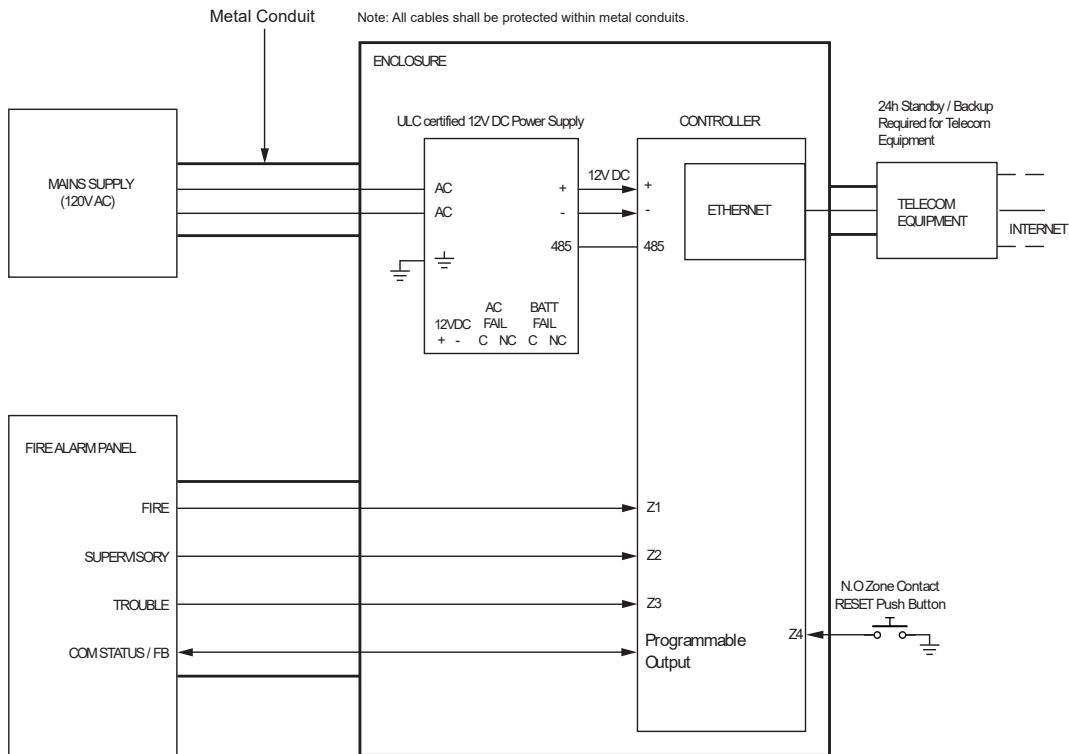

- * The AC FAIL output on the Power Supply **MUST** be programmed to follow the AC Trouble Input as follows:
AC FAIL = OPEN on fail
- * Fire zones shall be separated from burglar zones through area partitioning.
- * Fire zones Z1-Z3 shall be used exclusively for fire monitoring and cannot be programmed to activate the bell output
- * Fire Zone Z4 N.O Push Button to be used as monitoring reset switch.

Typical Zone Circuits

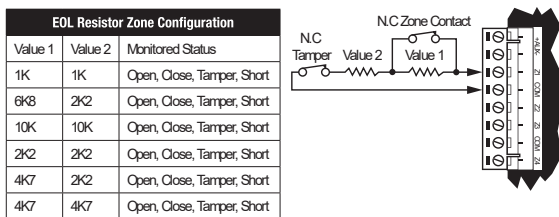

* EOL resistor must be installed at the Fire Alarm Control Panel Output.

CAN/ULC-S559
 CONTROLLER
 PASSIVE COMMUNICATION: MODEM DIALER

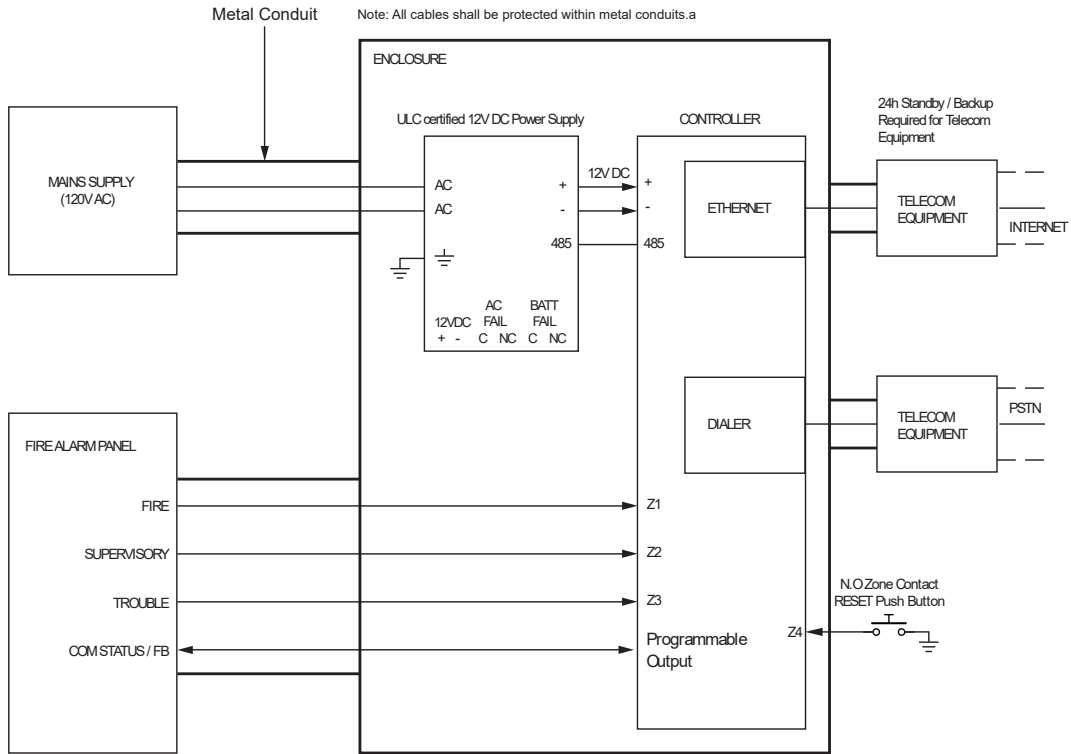

- * The AC FAIL output on the Power Supply MUST be programmed to follow the AC Trouble Input as follows:
AC FAIL = OPEN on fail
- * Fire zones shall be separated from burglar zones through area partitioning.
- * Fire zones Z1-Z3 shall be used exclusively for fire monitoring and cannot be programmed to activate the bell output
- * Fire Zone Z4 N.O Push Button to be used as monitoring reset switch.

Typical Zone Circuits

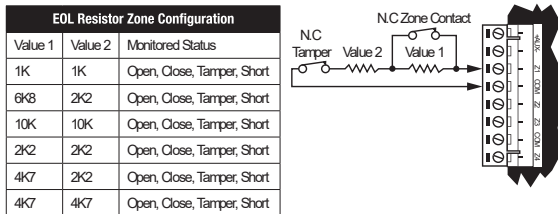

* EOL resistor must be installed at the Fire Alarm Control Panel Output.

CAN/ULC-S559
CONTROLLER
ACTIVE COMMUNICATION: CELLULAR MODEM

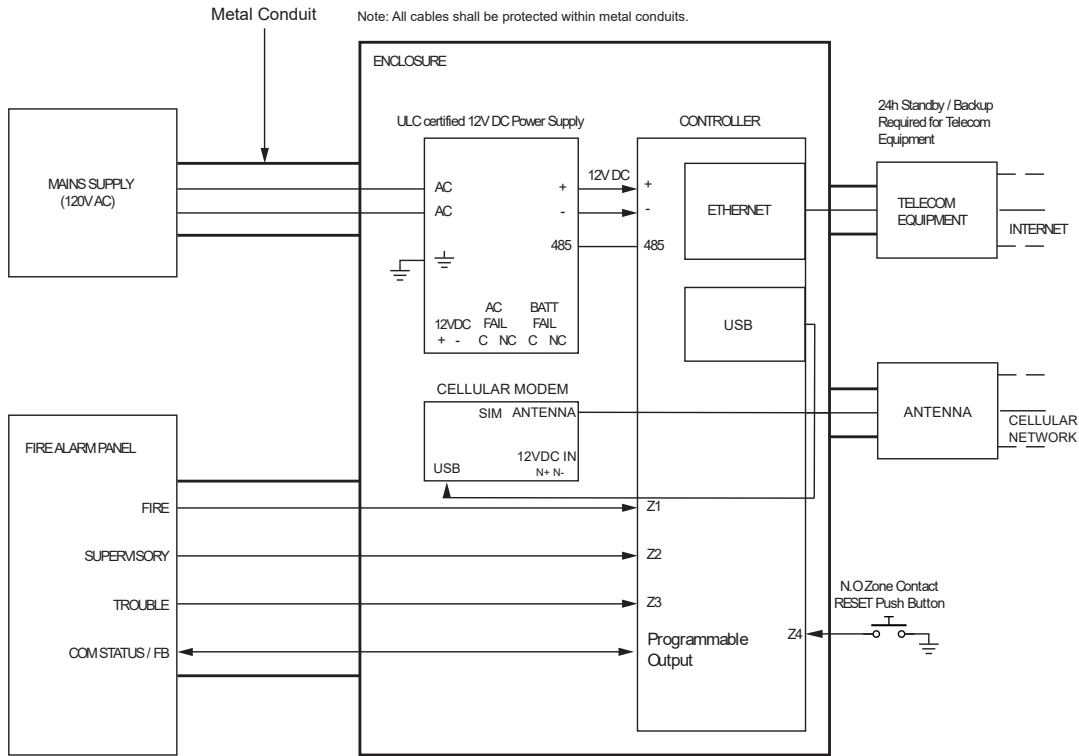

- * The AC FAIL output on the Power Supply MUST be programmed to follow the AC Trouble Input as follows:
AC FAIL = OPEN on fail
- * Fire zones shall be separated from burglar zones through area partitioning.
- * Fire zones Z1-Z3 shall be used exclusively for fire monitoring and cannot be programmed to activate the bell output
- * Fire Zone Z4 N.O Push Button to be used as monitoring reset switch.

Typical Zone Circuits

EOL Resistor Zone Configuration		
Value 1	Value 2	Monitored Status
1K	1K	Open, Close, Tamper, Short
6K8	2K2	Open, Close, Tamper, Short
10K	10K	Open, Close, Tamper, Short
2K2	2K2	Open, Close, Tamper, Short
4K7	2K2	Open, Close, Tamper, Short
4K7	4K7	Open, Close, Tamper, Short

* EOL resistor must be installed at the Fire Alarm Control Panel Output.

Fire area inputs must be programmed as follows:

- FACP Fire Alarm Signal input type must be programmed as Fire.
- Supervisory Trouble Signal input type must be programmed as 24 HR Silent.
- Trouble Signal input type must be programmed as 24 HR Silent.

Please refer to the section Inputs | Areas and Input Types in the Operator Reference Manual.

- All fire area inputs must be placed into an area and this area must be armed. Please refer to the section Inputs | Areas and Input Types in the Operator Reference Manual.
- COM Status

FACP system with a COM STATUS input must have this input connected to one of the dry relay contacts of the Relay1 or Relay2 outputs of the Protege controller and the selected output must be programmed as the Report OK output in the Contact ID Service.

Note: Any available dry relay contact on the Protege controller or output expander may be used for the FACP system, provided the selected output is programmed as the Report OK output.

Please refer to section Contact ID | Settings in the Operator Reference Manual.

- Fire inputs Z1-Z3 shall be used exclusively for fire monitoring and cannot be programmed to activate the bell output.

UL Compliance Requirements

UL1610

For Security Grade 4 installations, two forms of reporting are required. This can be satisfied using the onboard 2400bps modem included with the modem controller model, or through the incorporation of the PRT-4G-USB cellular modem module into the installation with the non-modem controller model.

- A local alarm sounding device, alarm housing, and control unit shall comply with the mercantile requirements in the Standard for Police Station Connected Burglar Alarm Units and Systems, UL365.
- A bell or visual indicator used as an arming acknowledgement signal must be listed to a UL security, signaling or fire standard. If intended to be mounted outside, it must be rated for outdoor use.
- Exit and entry delay must not exceed 60 seconds. To program the entry and exit delay time, refer to the section Areas | Configuration in the Operator Reference Manual.
- All ethernet network connections shall be installed within the same room as the equipment.
- Signals between the premises control unit and the receiving equipment, when not carried by wireless means, shall be protected by the following method:
 - Onboard modem telco connection must be dedicated to the Protege controller.

Modem model only.

- Ethernet connection to the Internet Service Provider (ISP) with a fixed IP Address must be dedicated to the Protege controller.
- To comply with the dual signal line transmission system requirement, both transmission lines (onboard modem and IP reporting) must be enabled. Signals shall be sent simultaneously to both the primary communications channel and the Backup Service.

The Report IP and Contact ID services must be programmed and enabled within the Protege system. The following options are required:

- The **Contact ID Reporting Service** must be enabled and the **Service Mode** must be configured to start with the operating system.
 - Refer to the section Contact ID in the Operator Reference Manual.
 - The **Report IP Service** must be enabled as the primary communication channel, the **Service Mode** must be configured to start with the operating system, and the **Reporting Protocol** must be set to ArmorIP.
 - Refer to the section Report IP in the Operator Reference Manual.
- When more than one means of signal transmission is used, loss of communication with the receiving system shall be annunciated at the receiver within 200 seconds. If a fault is detected on any of the signal transmission means, at least one of the signal transmission channels shall send a signal to the central-station to report the fault within 200 seconds.

The Report IP and Contact ID services must be programmed and enabled within the Protege system.

The Protege controller is compatible with the ArmorIP Internet Monitoring Receiver. Poll Time must be set to 40 seconds and the Grace Time must be set to 20 seconds.

In the Protege system, the reporting service must be configured to 40 seconds. The following options are required for the service selected as Report IP type:

- The **Poll Time** must be programmed to 40 seconds. Refer to the Report IP | General section in the Operator Reference Manual
 - The **Contact ID Reporting Service** must be enabled and the **Service Mode** must be configured to start with the operating system.
 - Refer to the section Contact ID in the Operator Reference Manual

- The **Report IP Service** must be enabled as the primary communication channel, the **Service Mode** must be configured to start with the operating system, and the **Reporting Protocol** must be set to ArmorIP.
- Refer to the section Report IP in the Operator Reference Manual.
- The **Trouble Input Area** must be armed in 24h mode. Refer to the section Trouble Inputs | Areas and Input Types in the Operator Reference Manual.

In the event of unsuccessful communication, a digital alarm communicator transmitter shall make a minimum of 5 and a maximum of 10 attempts. Where the maximum number of attempts to complete the sequence is reached, an indication of the failure shall be made at the premises.

In the Protege system, the reporting service selected as Contact ID must have the number of attempts programmed to 5 attempts. The following options are required:

- The **Dial Attempts** option must be programmed. Refer to the section Contact ID | Settings in the Operator Reference Manual.
- DACT communication channel check-in time is not to exceed 24 hrs.
- Trouble Zone Service Test Report
 - The **Test Report Time** must be programmed. Refer to the section Controllers | Configuration in the Operator Reference Manual.
 - The **Generate Input Restore on Test Input** option must be enabled. Refer to the section Controller | Options in the Operator Reference Manual.
 - The **Test Report Time is Periodic** option must be enabled. Refer to the section Controller | Options in the Operator Reference Manual.
 - ArmorIP detects the reception of any invalid packet on the programmed port as a potential system **compromise attempt**. Each compromise attempt sends a notification to the receiver, and logs a Compromise Attempt event under the Live Panel Events.

The event is sent with the following details:

- **Account Code** as defined in the Serial Receiver settings
- **Event Code** 0x163
- **Group Code** as defined in the Serial Receiver settings
- **Point Code** as defined in the Serial Receiver settings

Refer to the section Global Settings | Serial Receiver in the ArmorIP Version 3 Internet Monitoring Application User Manual.

For UL and ULC installations the Central Station Receiving software must have the Contact ID details as specified, programmed for the **Compromise Attempt** event.

- If a flexible cord is used to connect to line voltage, strain relief must be provided for the cord inside the enclosure or at the knockout.
- The power supply is not intended to be mounted on the exterior of vault, safe, or stockroom.
- **Hardwire Transformer Marcus M4758CT**
When installed with the power supply manufactured by Marcus, Model M4758CT, the Littelfuse Part No. 150322 fuseholder and Littelfuse Part No. 0312005 5A, 3AG fast-acting fuse must be installed in-line to the Power Supply.

UL294

- The Protege controller and reader expander module are intended to be mounted within the enclosure (refer to UL/ULC Installation Cabinet Options), installed inside the protected premise, and are UL 294 Listed for Attack Class I applications only.
- Exit devices and wiring must be installed within the protected area.
- For the Protege controller and reader expander module, all RS485 and reader terminal connections must be made using shielded grounded cable.
- All readers must be connected with shielded, grounded cable.
- A bell or visual indicator used as an arming acknowledgment signal must be listed to a UL security, signaling or fire standard. If intended to be mounted outside, it must be rated for outdoor use.

- Fail secure locking mechanism shall only be installed where allowed by the local authority having jurisdiction (AHJ) and shall not impair the operation of panic hardware and emergency egress.
- If fire resistance is required for door assembly, portal locking device(s) must be evaluated to UL10B or UL10C.
- Must be installed with UL 1034 listed electronic locks for UL installations.
- AC power on shall be indicated by an external panel mount LED (Lumex SSI-LXH312GD-150) and fitted into a dedicated 4mm hole in the cabinet to provide external visibility. This shall be wired between 12V and a PGM output that is programmed to follow the AC trouble input as shown below:

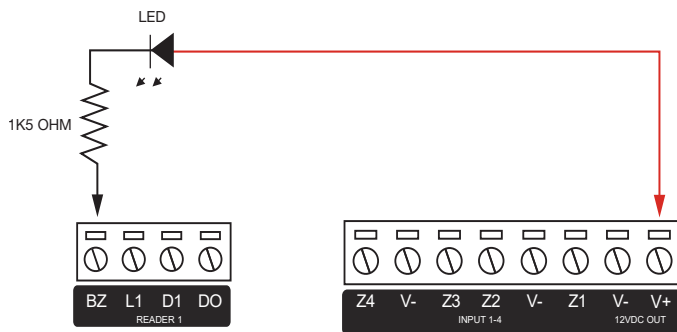

- If a flexible cord is used to connect to line voltage, strain relief must be provided for the cord inside the enclosure or at the knockout.
- The power supply is not intended to be mounted on the exterior of vault, safe, or stockroom.
- **Hardwire Transformer Marcus M4758CT**

When installed with the power supply manufactured by Marcus, Model M4758CT, the Littelfuse Part No. 150322 fuseholder and Littelfuse Part No. 0312005 5A, 3AG fast-acting fuse must be installed in-line to the Power Supply.

It is acceptable to use a Digital Security Controls (DSC) Model ULC-LA power indicator light assembly (Installation Instruction No. 29001877 R0) instead of the programmable AC indication method described above, which must be installed within a conduit knockout of the enclosure in order to provide green AC power on indication. Refer to AC Power Supply (see page 14).

FCC Compliance Statements

FCC Rules and Regulations CFR 47, Part 15, Subpart B

This equipment complies with the limits for a Class A digital device, pursuant to Part 15 of the FCC rules.

Operation is subject to the following two conditions:

- This device may not cause harmful interference.
- This device must accept any interference received, including interference that may cause undesired operation.

NOTE: THE GRANTEE IS NOT RESPONSIBLE FOR ANY CHANGES OR MODIFICATIONS NOT EXPRESSLY APPROVED BY THE PARTY RESPONSIBLE FOR COMPLIANCE. SUCH MODIFICATIONS COULD VOID THE USER'S AUTHORITY TO OPERATE THE EQUIPMENT.

Industry Canada Statement

ICES-003

This class A digital apparatus complies with Canadian ICES-003.

Cet appareil numérique de la classe A est conforme à la norme NMB-003 du Canada.

CAN ICES-3 (A)/NMB-3(A)

Disclaimer and Warranty

Disclaimer: Whilst every effort has been made to ensure accuracy in the representation of this product, neither Integrated Control Technology Ltd nor its employees shall be liable under any circumstances to any party in respect of decisions or actions they may make as a result of using this information. In accordance with the ICT policy of enhanced development, design and specifications are subject to change without notice.

For warranty information, see our [Standard Product Warranty](#).

Submitted to UL 31-May-23

Designers & manufacturers of integrated electronic access control, security and automation products.
Designed & manufactured by Integrated Control Technology Ltd.
Copyright © Integrated Control Technology Limited 2003-2023. All rights reserved.

Disclaimer: Whilst every effort has been made to ensure accuracy in the representation of this product, neither Integrated Control Technology Ltd nor its employees shall be liable under any circumstances to any party in respect of decisions or actions they may make as a result of using this information. In accordance with the ICT policy of enhanced development, design and specifications are subject to change without notice.